

# TourPacket

## “Chapter Zero”

**A tour of the fundamentals of Geometry  
from triangles to transformations.**

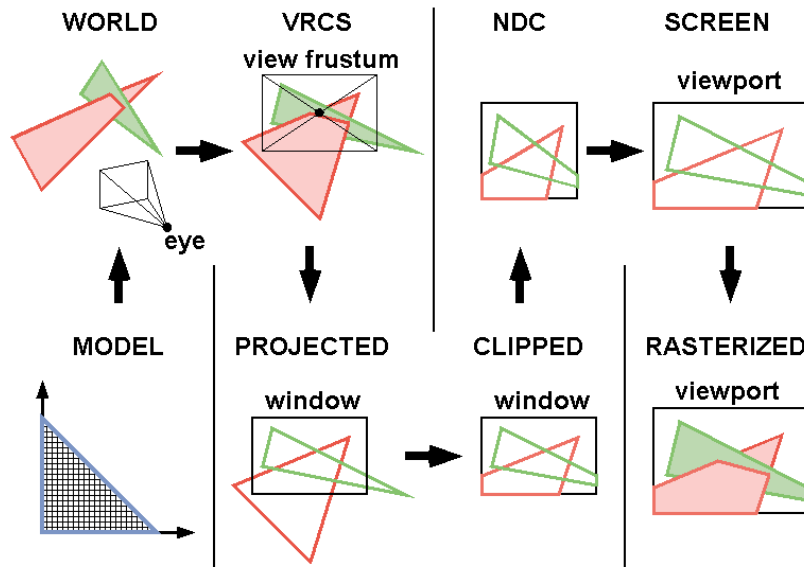

# Geometry

Geometry is the study of ...

- 
- 
- 
- 
- 
- 

- 
- 



-



Handwriting practice area consisting of multiple horizontal lines. The top two lines are green, and the remaining lines are black. A vertical red margin line is on the left.



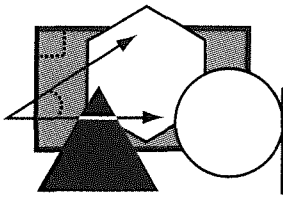

Name \_\_\_\_\_

# GEO-HUNT

Match Column A to Column B. Give a physical example of each item. Place the letter above the corresponding number below to answer the riddle.

Column A

Column B

Examples

1. Perpendicular lines

E.

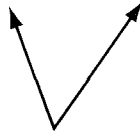

1. \_\_\_\_\_

2. Acute angle

G.

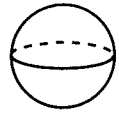

2. \_\_\_\_\_

3. Cylinder

H.



3. \_\_\_\_\_

4. Parallel lines

L.

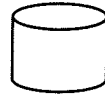

4. \_\_\_\_\_

5. Obtuse angle

N.



5. \_\_\_\_\_

6. Sphere

O.



6. \_\_\_\_\_

7. Rectangle

P.

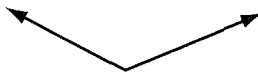

7. \_\_\_\_\_

8. Cone

R.

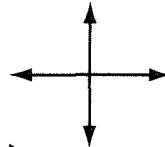

8. \_\_\_\_\_

9. Right triangle

Y.



9. \_\_\_\_\_

10. Cube

!



10. \_\_\_\_\_

What the geometry teacher who trains parrots found when she returned home:

\_\_\_\_\_ E \_\_\_\_\_  
8 1

\_\_\_\_\_ L \_\_\_\_\_  
5 4 3 9

\_\_\_\_\_ O \_\_\_\_\_  
6 7 2 10

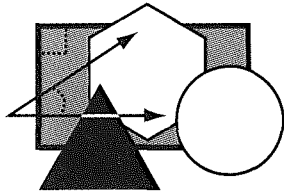

Name \_\_\_\_\_

# SOME ANGLE SUMS

Two angles are **complementary** if the sum of their measures is  $90^\circ$ .

Two angles are **supplementary** if the sum of their measures is  $180^\circ$ .

Tell if each angle pair is complementary (C), supplementary (S), or neither (N).

- |                                |                                |                               |
|--------------------------------|--------------------------------|-------------------------------|
| 1. $45^\circ, 55^\circ$ _____  | 2. $145^\circ, 35^\circ$ _____ | 3. $25^\circ, 65^\circ$ _____ |
| 4. $170^\circ, 10^\circ$ _____ | 5. $37^\circ, 113^\circ$ _____ | 6. $15^\circ, 75^\circ$ _____ |

Complete the table:

Angle	Complement	Supplement
7. $85^\circ$		
8. $12^\circ$		
9. $27^\circ$		
10. $30^\circ$		
11. $1^\circ$		

The measure of an **acute** angle is less than  $90^\circ$ . The measure of an **obtuse** angle is between  $90^\circ$  and  $180^\circ$ . State whether the following statements are true.

12. Two acute angles can be complementary. \_\_\_\_\_
13. Two acute angles can be supplementary. \_\_\_\_\_
14. Two obtuse angles can be complementary. \_\_\_\_\_
15. Two obtuse angles can be supplementary. \_\_\_\_\_
16. An acute angle and an obtuse angle can be supplementary. \_\_\_\_\_

Use these angles:

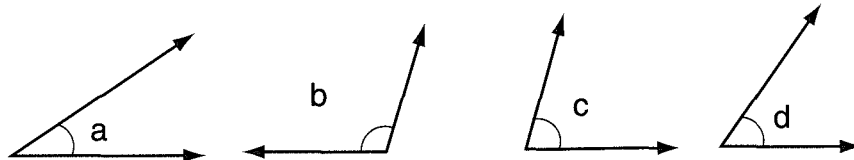

17. Which pair of angles could be complementary? \_\_\_\_\_
18. Which pair of angles could be supplementary? \_\_\_\_\_

In the diagram:

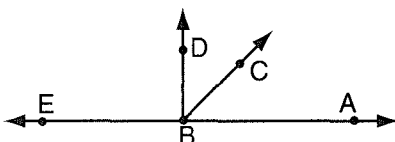

19. Angle ABC and angle \_\_\_\_\_ are complementary.
20. Angle ABC and angle \_\_\_\_\_ are supplementary.

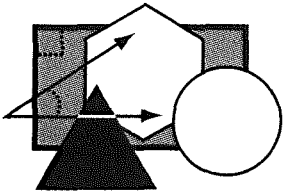

Name \_\_\_\_\_

# MANGLED ANGLES

Given: The three angles of a triangle total  $180^\circ$ .  
 Two adjacent angles that form a straight line total  $180^\circ$ .

Without measuring, determine the measures of each indicated angle in the diagram below.

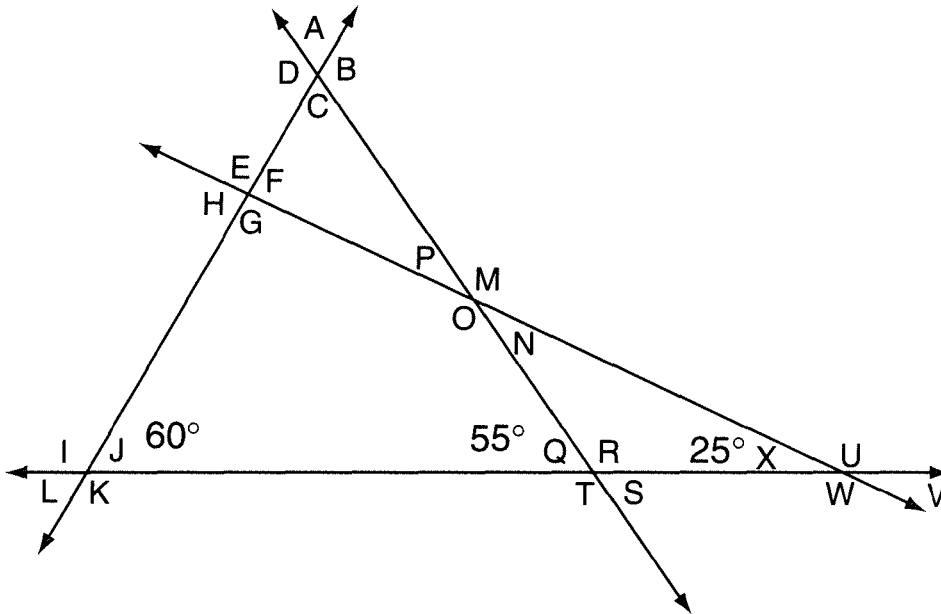

- |               |               |          |               |
|---------------|---------------|----------|---------------|
| A. _____      | B. _____      | C. _____ | D. _____      |
| E. _____      | F. _____      | G. _____ | H. _____      |
| I. _____      | J. <u>60°</u> | K. _____ | L. _____      |
| M. _____      | N. _____      | O. _____ | P. _____      |
| Q. <u>55°</u> | R. _____      | S. _____ | T. _____      |
| U. _____      | V. _____      | W. _____ | X. <u>25°</u> |

Find the sum of all the angles. \_\_\_\_\_  
 How is the product  $6 \times 360^\circ$  related to the angle sum?

\_\_\_\_\_

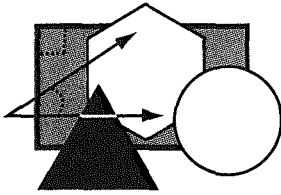

Name \_\_\_\_\_

## UP, UP, AND AWAY

Use a ruler and protractor and carefully follow the directions.

1. Locate point A 1 inch from the bottom and 1 inch from the right side of the page.
2. Draw  $\overline{AB}$   $\frac{3}{4}$  inch long parallel to the bottom of the page so B is  $1\frac{3}{4}$  inches from the right side of the paper.
3. Draw  $\overline{BC}$  1 inch long and  $\angle ABC$  is  $150^\circ$ . (C is above  $\overline{AB}$ .)
4. Draw  $\overline{CD}$  1 inch long and  $\angle BCD$  is  $150^\circ$ . (D is above  $\overline{BC}$ .)
5. Draw  $\overline{DE}$  2 inches long and  $\angle CDE$  is  $150^\circ$ . (E is on the same side of  $\overline{CD}$  as B.)
6. Draw  $\overline{EF}$   $1\frac{1}{2}$  inch long and  $\angle DEF$  is  $100^\circ$ . (F and B are on opposite sides of  $\overline{DE}$ .)
7. Draw  $\overline{FG}$   $1\frac{1}{2}$  inch long and  $\angle EFG$  is  $90^\circ$ . (G and E are on opposite sides of  $\overline{CD}$ .)
8. Connect G to D, G to E, and F to D.
9. Draw  $\overline{BH}$  and  $\overline{BJ}$   $\frac{1}{2}$  inch long.  $\angle ABH$  and  $\angle ABJ$  are  $90^\circ$ .
10. Draw  $\overline{BK}$  and  $\overline{BL}$   $\frac{1}{2}$  inch long.  $\angle CBK$  and  $\angle CBL$  are  $90^\circ$ . (H is on the same side of  $\overline{AB}$  as K.)
11. Connect H to K and connect J to L.
12. Draw  $\overline{CM}$  and  $\overline{CN}$   $\frac{1}{2}$  inch long.  $\angle BCM$  and  $\angle BCN$  are  $90^\circ$ .
13. Draw  $\overline{CO}$  and  $\overline{CP}$   $\frac{1}{2}$  inch long.  $\angle DCO$  and  $\angle DCP$  are  $90^\circ$ . (M is on the same side of  $\overline{BC}$  as O.)
14. Connect M to O and connect N to P.

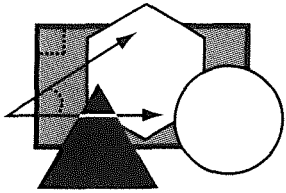

Name \_\_\_\_\_

# METRIC LENGTHS

Circle the best estimate for each measurement. Use the letters of the answers to complete the riddle below.

- |   |            |            |            |
|---|------------|------------|------------|
| 1. Diameter of a basketball               | R. 75 cm   | S. 24 cm   | T. 12 cm   |
| 2. Height of a door                       | L. 250 m   | M. 25 m    | N. 2.5 m   |
| 3. Length of a paper clip                 | A. 30 mm   | B. 30 cm   | C. 3 m     |
| 4. Thickness of a math textbook           | B. 2 m     | C. 2 cm    | D. 2 mm    |
| 5. Width of a neighborhood street         | P. 100 cm  | R. 10 m    | S. 1000 mm |
| 6. Distance from Chicago to New York City | C. 10 km   | D. 100 km  | E. 1000 km |
| 7. Diameter of a golf ball                | S. 4.3 mm  | T. 43 mm   | U. 43 cm   |
| 8. Diameter of a strand of hair           | E. 0.1 mm  | F. 1 mm    | G. 10 mm   |
| 9. Width of notebook paper                | I. 21.5 mm | E. 2.15 cm | A. 21.5 cm |
| 10. Length of a marathon                  | L. 420 cm  | M. 42 km   | N. 420 km  |
| 11. Length of a golf fairway              | C. 3.5 m   | D. 35 m    | E. 350 m   |
| 12. Width of a refrigerator               | S. 900 cm  | T. 90 cm   | U. 9 cm    |

What did the mathematician use to detect odors?

3    1    4    6    2    12    9    10    8    7    11    5

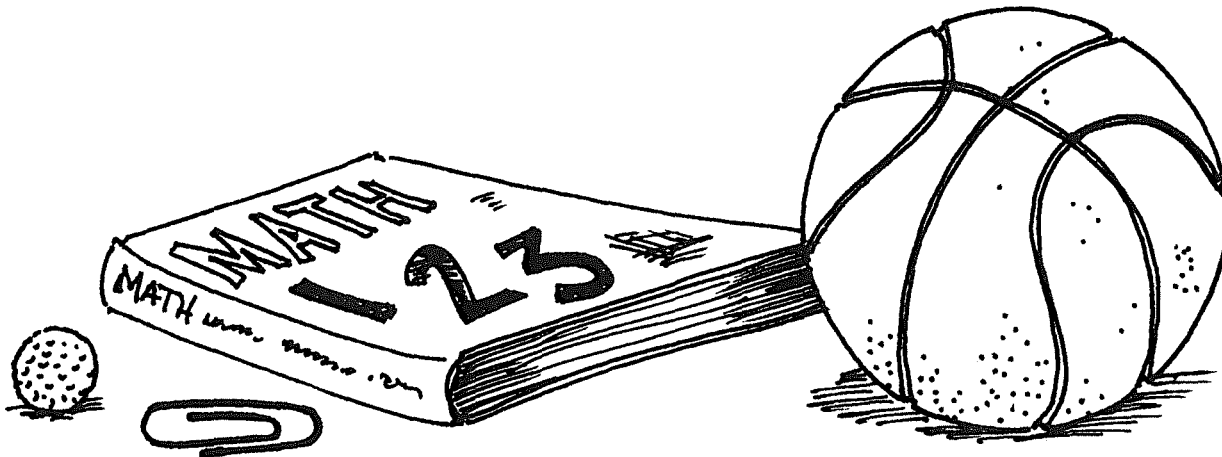

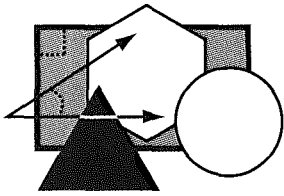

Name \_\_\_\_\_

# POLYGON SEARCH

Sort the following polygons. Place the letters of the polygons in the corresponding region in the box at the bottom of the page.

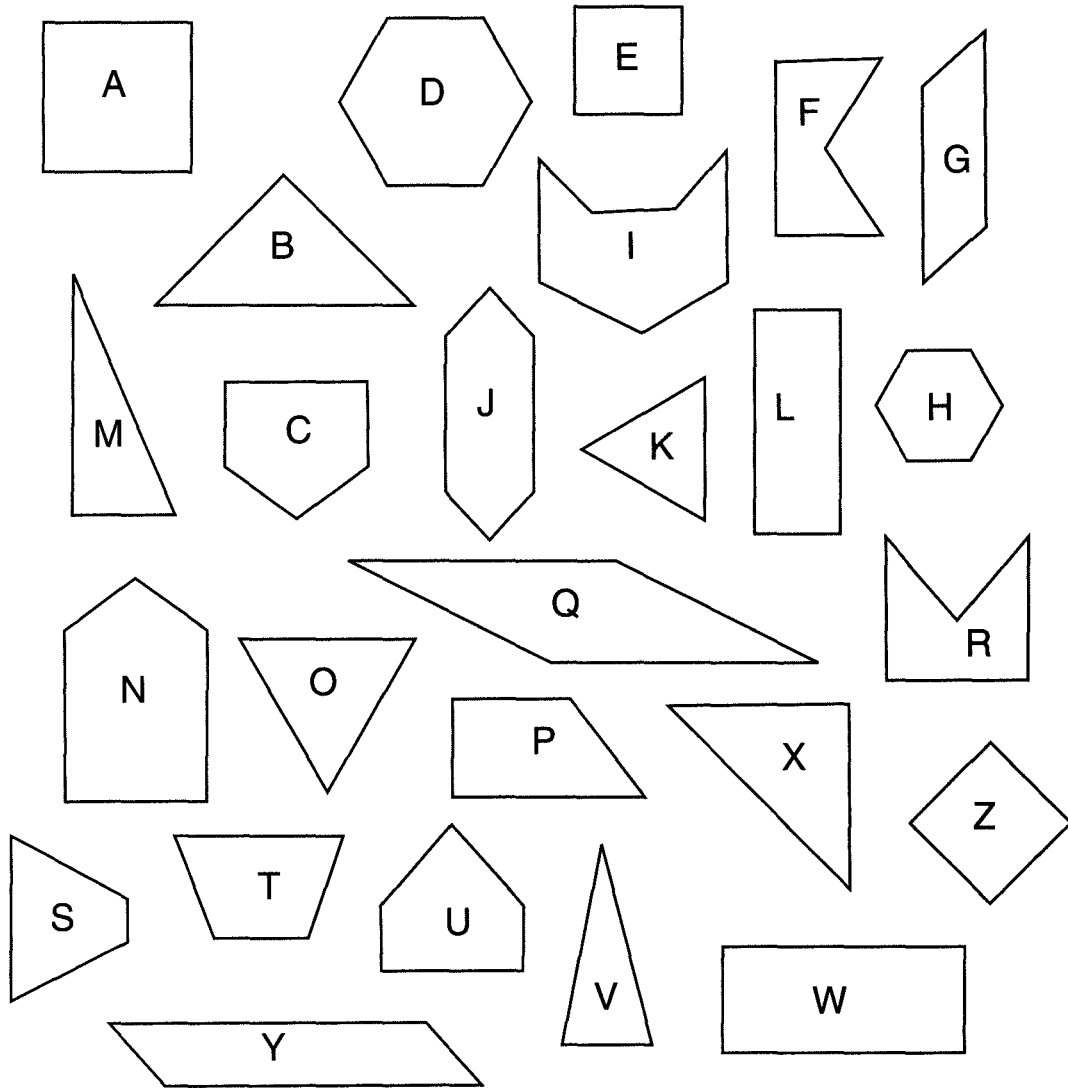

Triangles	Pentagons
Quadrilaterals	Closed Shapes

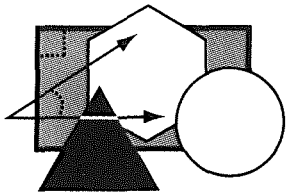

Name \_\_\_\_\_

# IN THE QUAD

Place the following terms in the diagram. Use each term only once.

square, quadrilateral, rhombus, rectangle, parallelogram, trapezoid

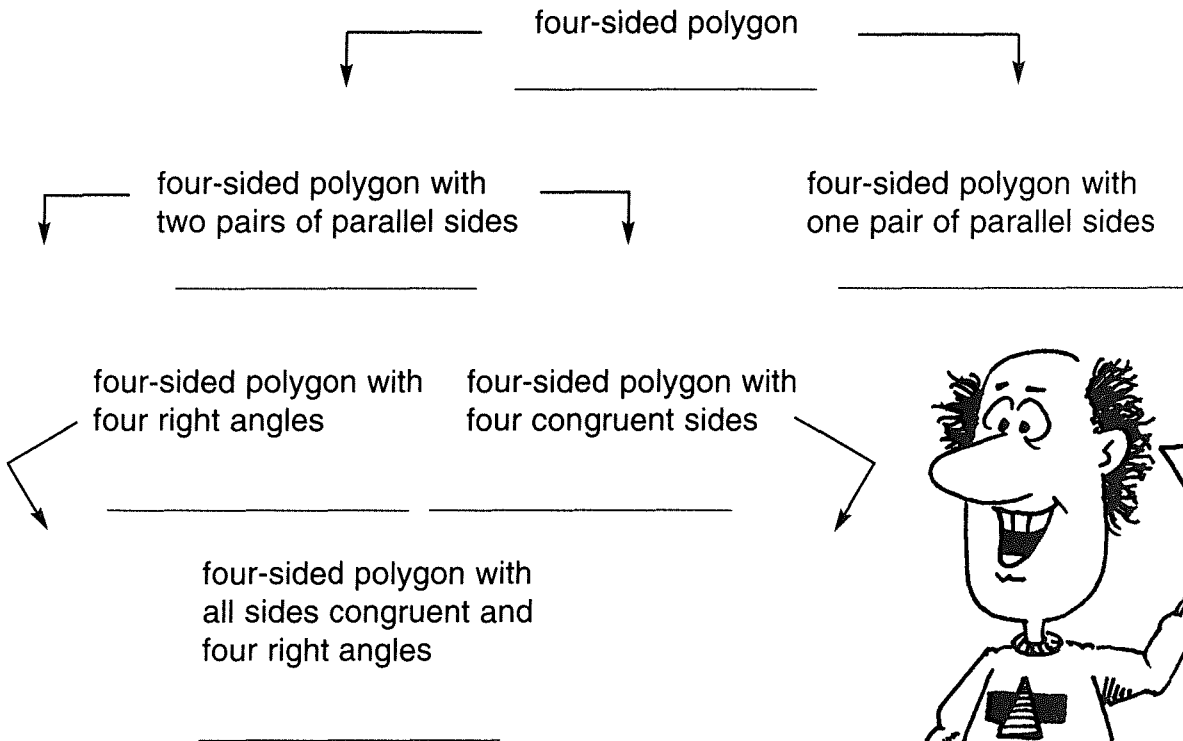

Use **all**, **some**, or **no** to complete each statement.

1. \_\_\_\_\_ squares are rectangles.
2. \_\_\_\_\_ parallelograms are rectangles.
3. \_\_\_\_\_ trapezoids are rectangles.
4. \_\_\_\_\_ parallelograms are rhombuses.
5. \_\_\_\_\_ rectangles are squares.
6. \_\_\_\_\_ squares are rhombuses.
7. \_\_\_\_\_ parallelograms are quadrilaterals.
8. \_\_\_\_\_ squares are parallelograms.
9. \_\_\_\_\_ rectangles are parallelograms.
10. \_\_\_\_\_ trapezoids are parallelograms.

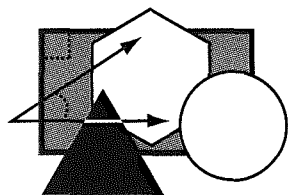

Name \_\_\_\_\_

# DIVIDE AND COUNT

The fact that the three angles of a triangle total  $180^\circ$  can be used to determine the angle sum of any polygon.

Draw diagonals to divide each polygon into triangles. Calculate the angle sum of each polygon.

Example:

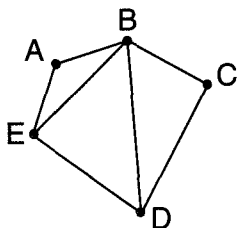

$$3 \text{ triangles} \times 180^\circ/\text{triangle} = 540^\circ$$

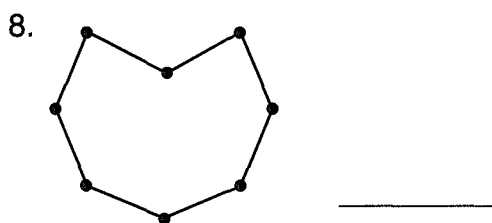
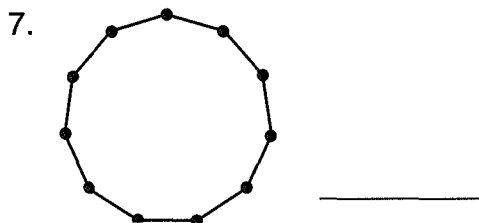
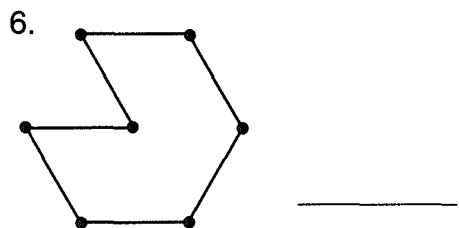
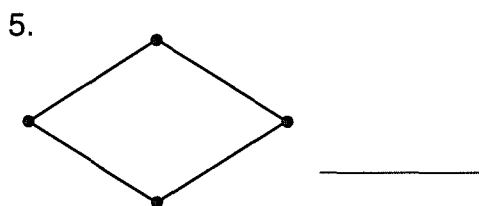
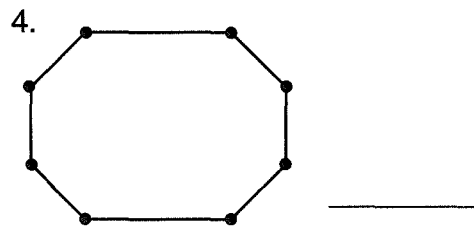
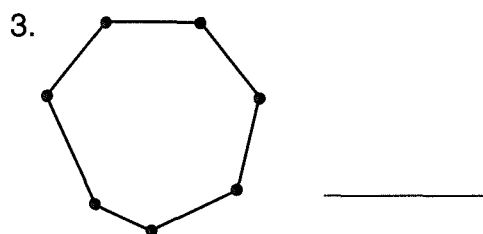
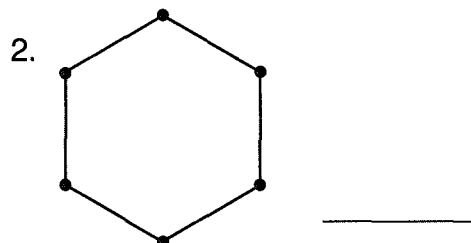
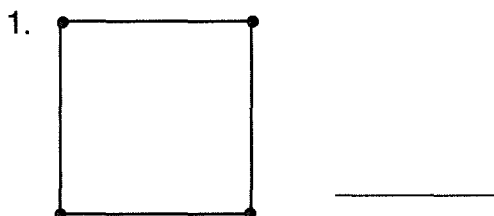

9. Write a math statement showing the relationship between the number of sides (N) and the number of triangles (T): \_\_\_\_\_

10. Write a formula for the angle sum (S) in terms of N: \_\_\_\_\_

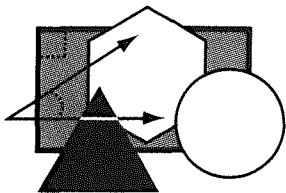

Name \_\_\_\_\_

# TRYING TO BE A TRIANGLE

- On another sheet of paper, try to draw triangles with the following side lengths:  
 A. 2 in., 3 in., 6 in.    B. 2 in., 4 in., 6 in.    C. 2 in., 5 in., 6 in.    D. 4 in., 4 in., 6 in.
- Which triangle(s) were you able to draw? \_\_\_\_\_

The **Triangle Inequality** states that the sum of any two sides of a triangle is greater than the length of the third side.

Write yes or no to indicate if the three given lengths can be the sides of a triangle.

- 7 cm, 2 cm, 4 cm \_\_\_\_\_
- 5 cm, 8 cm, 5 cm \_\_\_\_\_
- 2 in., 3 in., 4 in. \_\_\_\_\_
- 3.7 m, 4.6 m, 8.1 m \_\_\_\_\_
- On another sheet of paper, use a protractor and try to draw triangles with the following angle measures:  
 E.  $30^\circ$ ,  $90^\circ$ ,  $60^\circ$     F.  $20^\circ$ ,  $40^\circ$ ,  $60^\circ$     G.  $150^\circ$ ,  $10^\circ$ ,  $20^\circ$     H.  $40^\circ$ ,  $40^\circ$ ,  $40^\circ$
- Which triangle(s) were you able to draw? Why? \_\_\_\_\_
- The angle sum of any triangle is \_\_\_\_\_.

Consider the triangle shown.

- Which angle appears to be the largest? \_\_\_\_\_  
the smallest? \_\_\_\_\_
- Which side appears to be the longest? \_\_\_\_\_  
the shortest? \_\_\_\_\_
- In a triangle, the longest side is opposite the \_\_\_\_\_ angle.

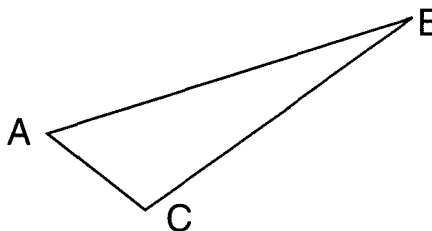

For each triangle, list the sides of the triangle from shortest to longest.

13.

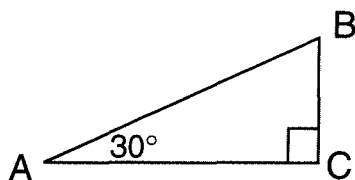

14.

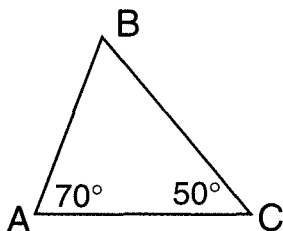

15.

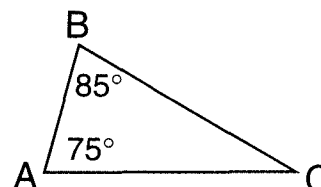

- The sides of the right triangle XYZ are 5 cm, 12 cm, and 13 cm. What is the length of the side opposite the  $90^\circ$  angle? Why? \_\_\_\_\_

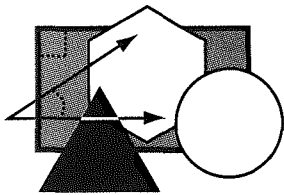

Name \_\_\_\_\_

# TRIANGLES FROM A DIFFERENT ANGLE

Triangles can be classified by their angle measures. An **acute triangle** has three acute angles. An **obtuse triangle** has one obtuse angle. A **right triangle** has one right angle.

Classify each triangle by angle.

1.

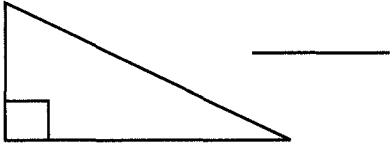

2.

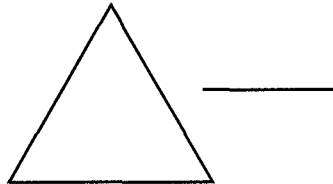

3.

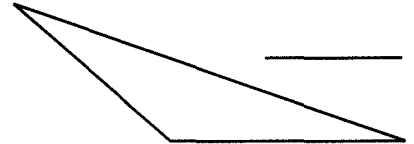

4. Can a right triangle contain an obtuse angle? Why? \_\_\_\_\_

Triangles can be classified by their side lengths. An **equilateral triangle** has three sides congruent. An **isosceles triangle** has two sides congruent. A **scalene triangle** has no sides congruent.

Classify each triangle by side length.

5.

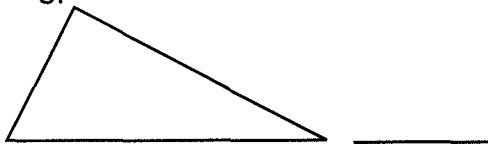

6.

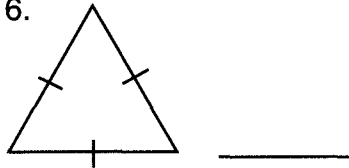

7.

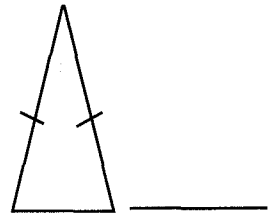

8. Can an equilateral triangle be a right triangle? Why? \_\_\_\_\_

Draw an example of each triangle. Write none if figure is not possible.

9. Right isosceles triangle

10. Obtuse scalene triangle

11. Obtuse equilateral triangle

12. Acute isosceles triangle

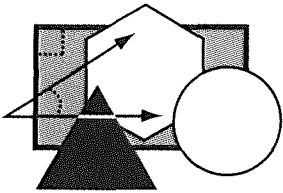

Name \_\_\_\_\_

# TAKING SIDES

The triangles drawn below are called **30-60-90 triangles** because the measures of the angles are 30°, 60°, and 90°. Carefully measure all three sides (to the nearest mm) of each of the triangles. Calculate the various ratios (to the nearest hundredth).

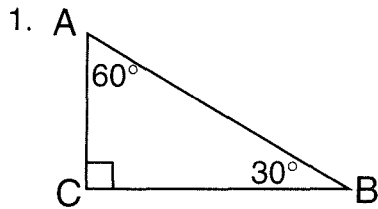

AC = \_\_\_\_\_ BC = \_\_\_\_\_ AB = \_\_\_\_\_

AB/AC = \_\_\_\_\_ BC/AC = \_\_\_\_\_

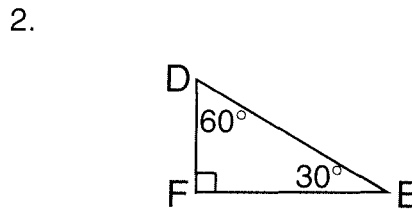

DF = \_\_\_\_\_ EF = \_\_\_\_\_ DE = \_\_\_\_\_

DE/DF = \_\_\_\_\_ EF/DF = \_\_\_\_\_

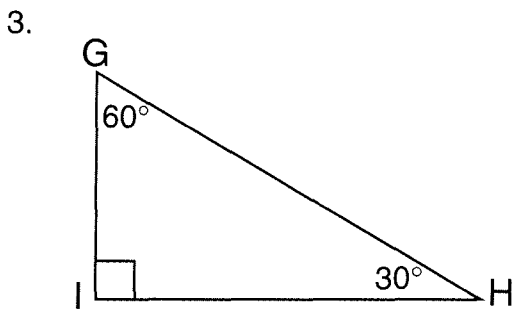

GI = \_\_\_\_\_ HI = \_\_\_\_\_ GH = \_\_\_\_\_

GH/GI = \_\_\_\_\_ HI/GI = \_\_\_\_\_

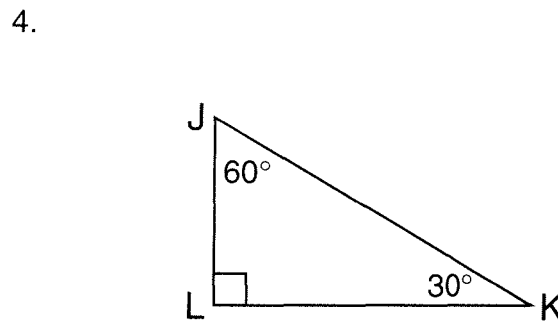

JL = \_\_\_\_\_ KL = \_\_\_\_\_ JK = \_\_\_\_\_

JK/JL = \_\_\_\_\_ KL/JL = \_\_\_\_\_

- What is the relationship between the hypotenuse and the side opposite the 30° angle? \_\_\_\_\_
- Use a calculator or a table of roots to find the  $\sqrt{3}$ . \_\_\_\_\_
- What is the relationship between the side opposite the 60° angle and the side opposite the 30° angle? \_\_\_\_\_
- Given that the side opposite a 30° angle in a 30-60-90 triangle measures 215 mm, what is the measure of the hypotenuse? \_\_\_\_\_ What is the measure of the side opposite the 60° angle? \_\_\_\_\_

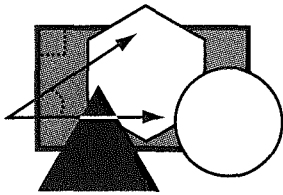

Name \_\_\_\_\_

# PYTHAGOREAN THREESOME

The Pythagorean Theorem results in the following relationship among the three sides of a right triangle:

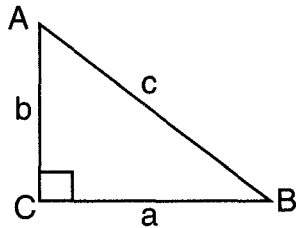

$$a^2 + b^2 = c^2$$

$$\text{leg}^2 + \text{leg}^2 = \text{hypotenuse}^2$$

Use the Pythagorean Theorem to find the missing side.

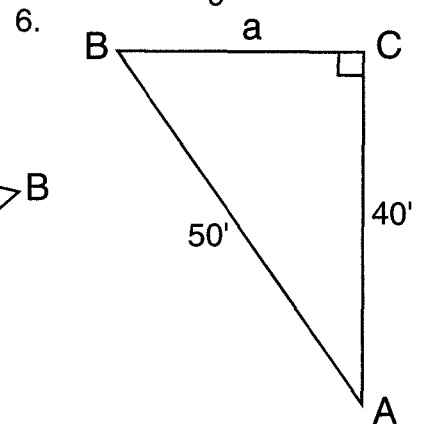
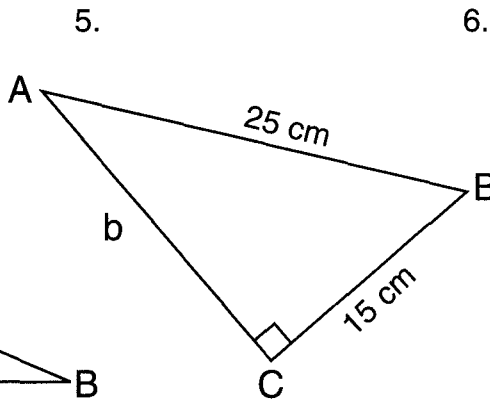
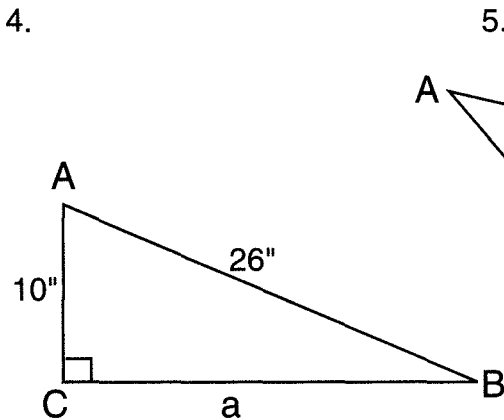
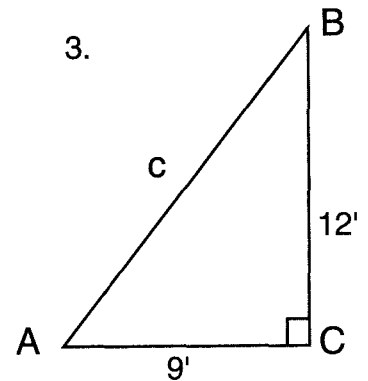
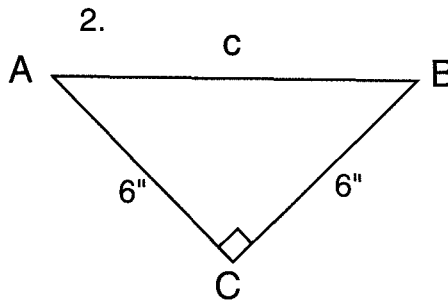
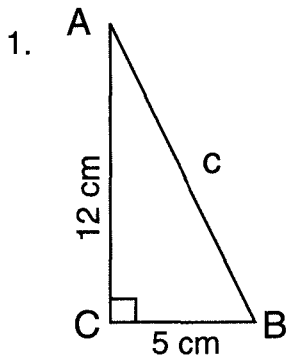

Any three positive numbers (a, b, c) that satisfy the  $a^2 + b^2 = c^2$  relationship can be the lengths of the sides of right triangles. The set of three numbers is called a **Pythagorean triple**.

Are the following sets of numbers Pythagorean triples?

7. (1, 1, 2) \_\_\_\_\_

8. (6, 8, 10) \_\_\_\_\_

9. (1, 2, 3) \_\_\_\_\_

10. (5, 12, 13) \_\_\_\_\_

11. (2, 3, 4) \_\_\_\_\_

12. (3, 4, 5) \_\_\_\_\_

13. How do the sides of triangle #4 compare to the numbers in #10? \_\_\_\_\_

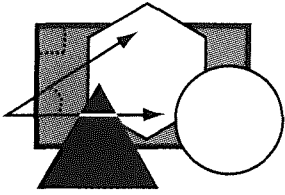

Name \_\_\_\_\_

# SPECIAL TRIANGLE SEGMENTS

Four special segments associated with triangles are drawn below.

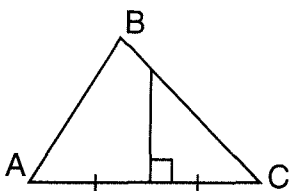

Perpendicular Bisector

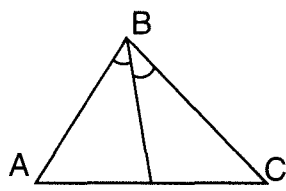

Angle Bisector

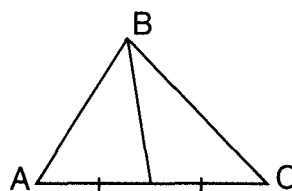

Median

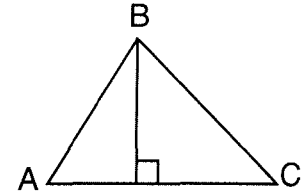

Altitude

1. What do the perpendicular bisector and median have in common?

\_\_\_\_\_

2. What do the perpendicular bisector and altitude have in common?

\_\_\_\_\_

Cut four large acute scalene triangles from paper. Label them A, B, C, and D.

3. A: Fold and crease so one vertex aligns with another—perpendicular bisector.
- B: Fold and crease so one side aligns with another—angle bisector.
- C: Locate the midpoint of one side. Fold and crease from that midpoint to the opposite vertex—median.
- D: Fold and crease the line from a vertex to the opposite side so a part of that side aligns with the other part of that side—altitude.

4. Use the triangles from #3 and repeat the directions for the other two vertices or sides. What do you notice for each triangle?

5. The medians intersect at the **centroid**, which is the center of gravity. The centroid of any figure can be found by doing the following:

1. Cut the shape out of cardboard.
2. Make a plumb line out of a paper clip, string, and weight (washer, nut, etc.).
3. Punch a small hole near each side.
4. For each hole, balance the shape on a paper clip.
5. Use the plumb line to draw a vertical line.
6. The lines intersect at the centroid.
7. The figure will balance on a pencil tip or eraser at the centroid.

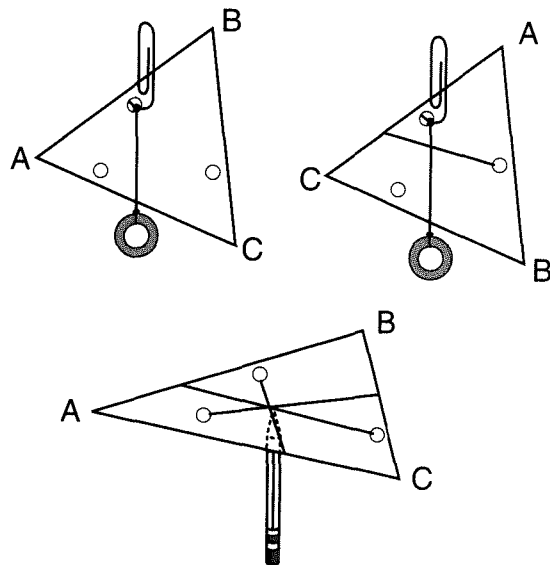

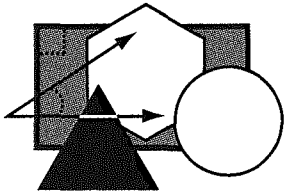

Name \_\_\_\_\_

# AROUND THE CORNER

**Perimeter** literally means “measure around.” To calculate the perimeter of any polygon, add the lengths of all the sides.

Find the perimeter of each figure.

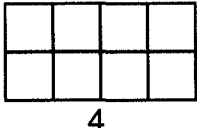
Ex.   $P = 4 + 2 + 4 + 2$   
 $P = 12$

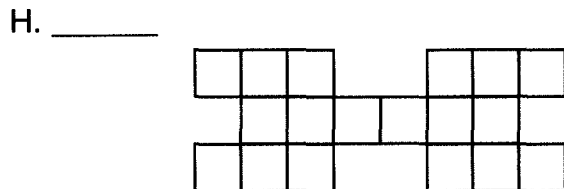
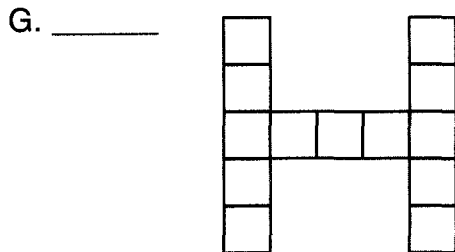
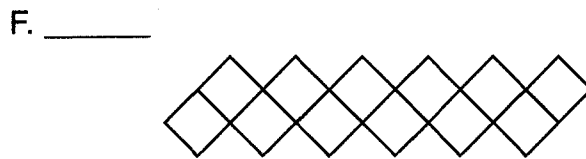
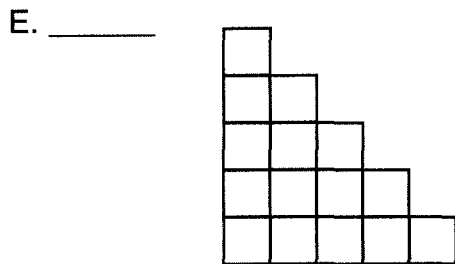
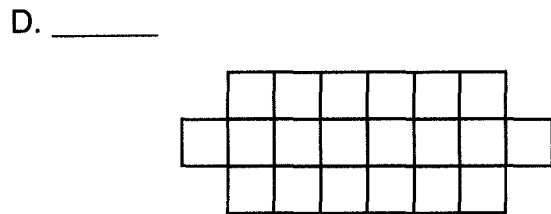
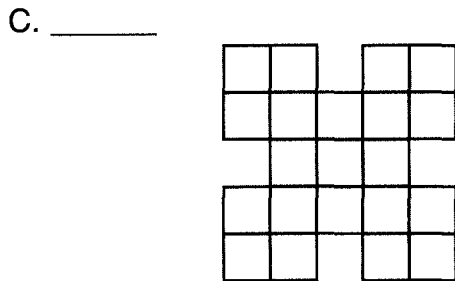
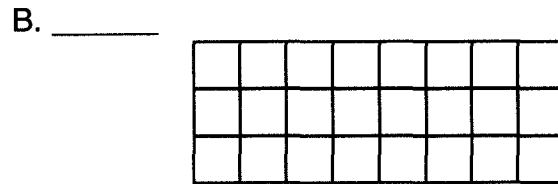
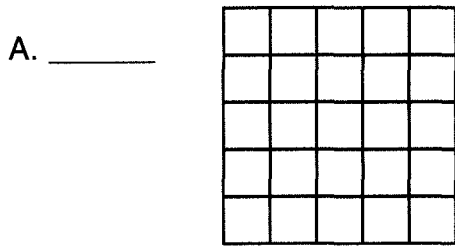

$(A + B) + C - (D + E) - F + G - H = \underline{\hspace{2cm}}$

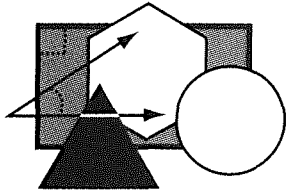

Name \_\_\_\_\_

# PERIMETER VS. AREA

Complete the following activities to discover a relationship between perimeter and area.

1. On the grid, draw four rectangles with integer dimensions that have areas equal to 24 sq. units but different perimeters. Label the rectangles A, B, C, and D.

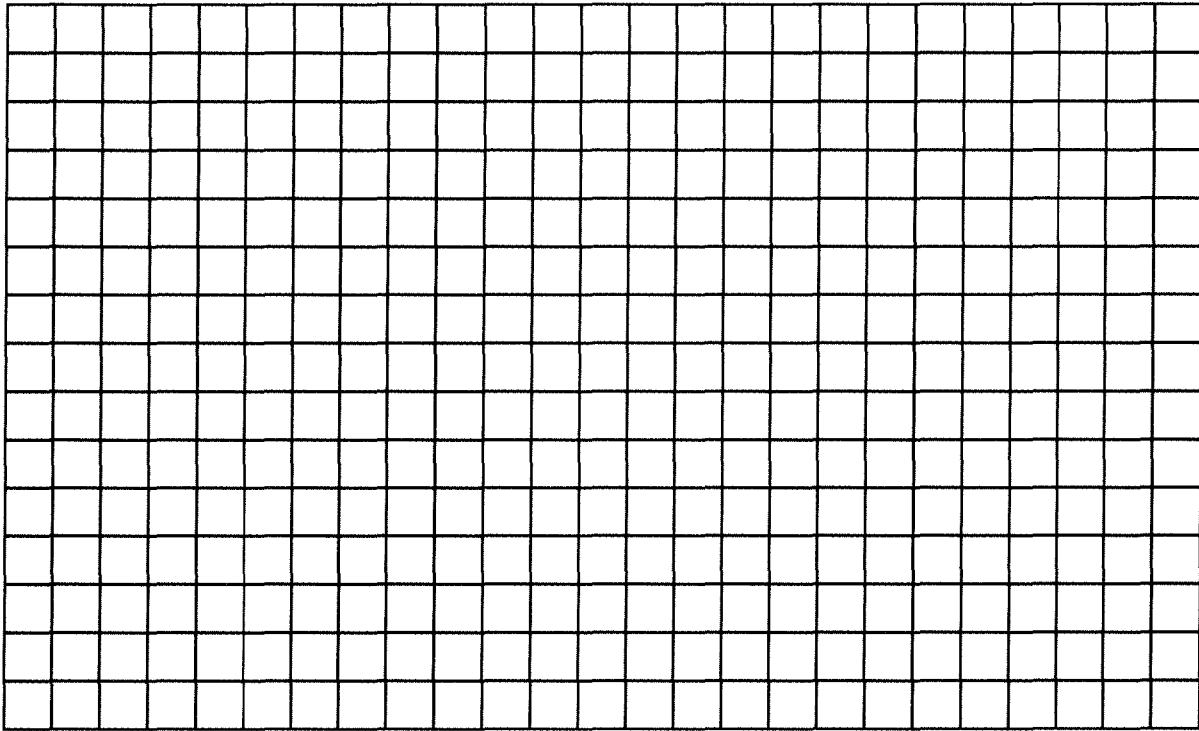

Find the perimeters:    A \_\_\_\_\_    B \_\_\_\_\_    C \_\_\_\_\_    D \_\_\_\_\_

Give the dimensions of the rectangle with the least perimeter: \_\_\_\_\_ by \_\_\_\_\_

What do you observe about the perimeters of objects having the same area?

---

---

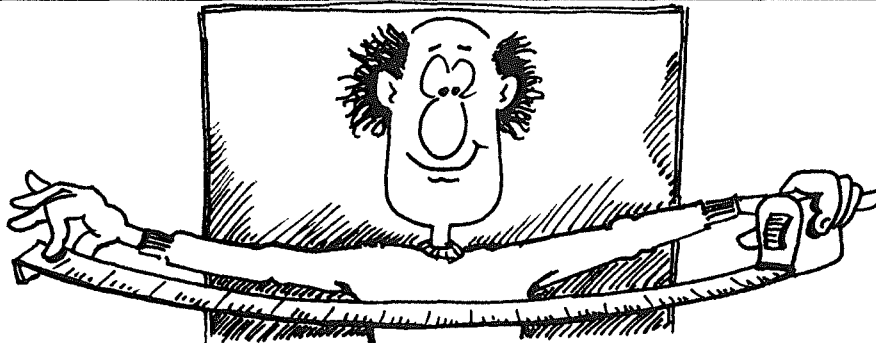

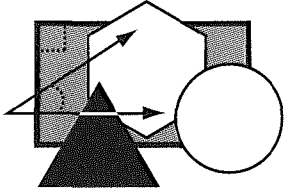

Name \_\_\_\_\_

# DOUBLE TROUBLE

1. Find the perimeter and area of a 4" by 6" rectangle.

$P_1 = \underline{\hspace{2cm}}$        $A_1 = \underline{\hspace{2cm}}$

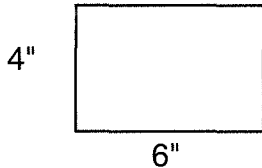

- 2a. Find the perimeter and area of a 4" by 12" rectangle.

$P_2 = \underline{\hspace{2cm}}$        $A_2 = \underline{\hspace{2cm}}$

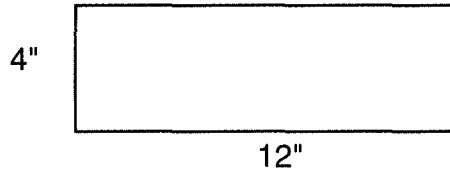

- 2b. How does  $A_2$  compare to  $A_1$ ?

- 3a. Find the perimeter and area of an 8" by 12" rectangle.

$P_3 = \underline{\hspace{2cm}}$        $A_3 = \underline{\hspace{2cm}}$



4. Start with a 5 cm by 8 cm picture. Find the perimeter and area.

$P_4 = \underline{\hspace{2cm}}$        $A_4 = \underline{\hspace{2cm}}$

- 5a. Triple both dimensions:  
 \_\_\_\_\_ cm by \_\_\_\_\_ cm  
 Find the perimeter and area.  
 $P_5 = \underline{\hspace{2cm}}$        $A_5 = \underline{\hspace{2cm}}$

- 3b. How does  $P_3$  compare to  $P_1$ ? \_\_\_\_\_

- 5b. How does  $P_5$  compare to  $P_4$ ? \_\_\_\_\_

- 3c. How does  $A_3$  compare to  $A_1$ ? \_\_\_\_\_

6. How does  $A_5$  compare to  $A_4$ ? \_\_\_\_\_

**BONUS:** How would the perimeter and area of a rectangle with quadrupled dimensions compare with the perimeter and area of the original rectangle?

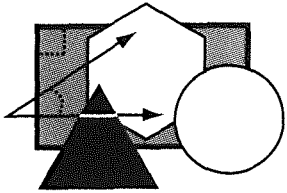

Name \_\_\_\_\_

# WHAT'S IN A NAME?

Let each  $\blacksquare$  represent 1 square unit. Find the area of each letter, then calculate the area of your name.

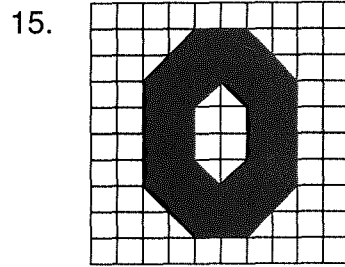
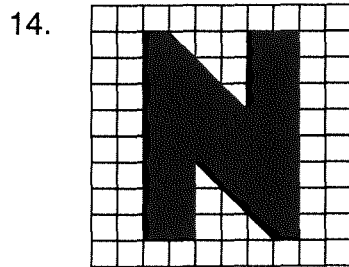
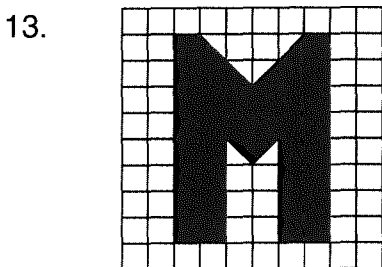
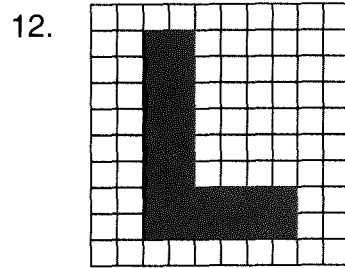
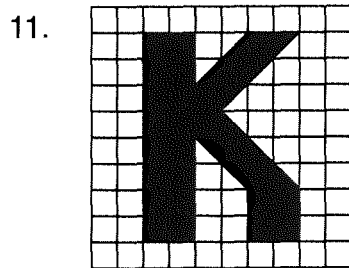
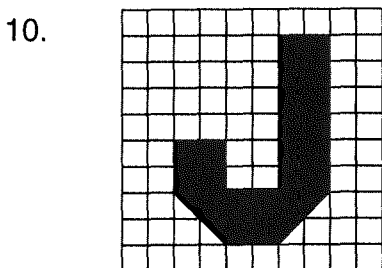
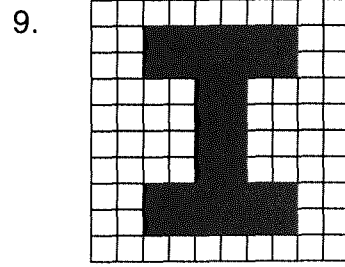
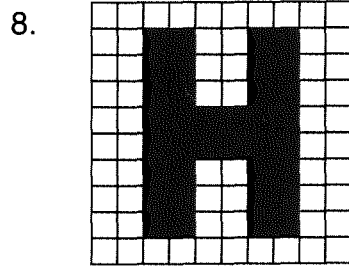
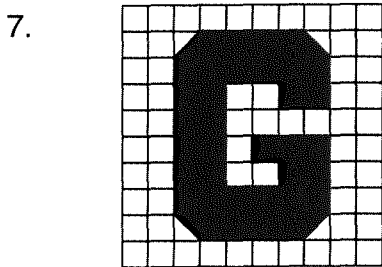
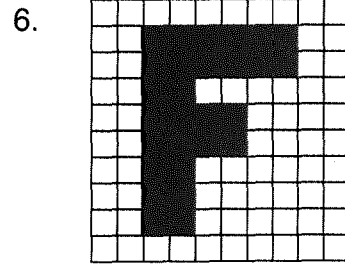
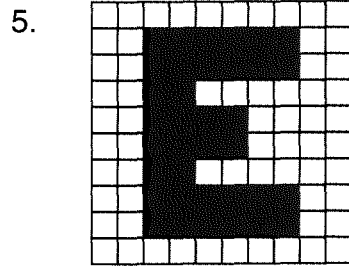
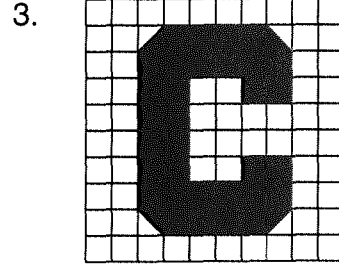
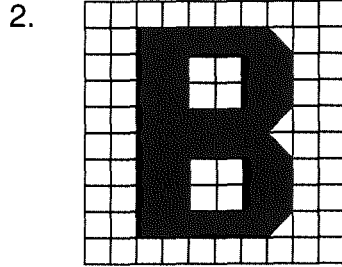
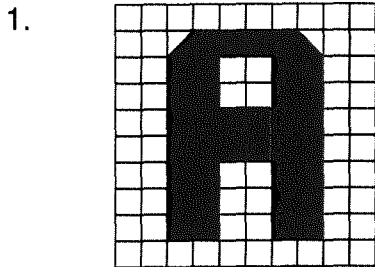

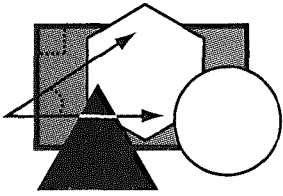

Name \_\_\_\_\_

16.

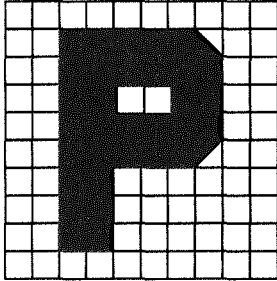

17.

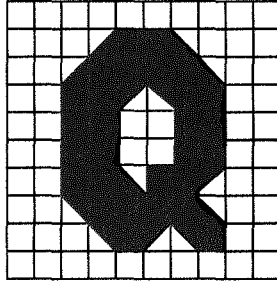

18.

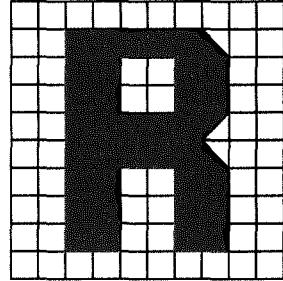

19.

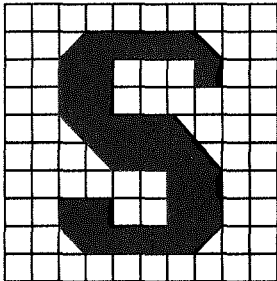

20.

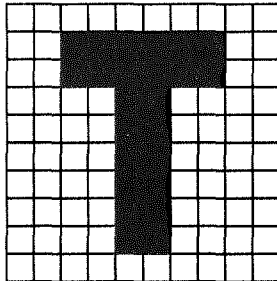

21.

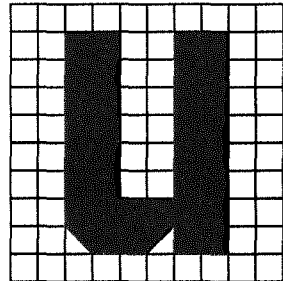

22.

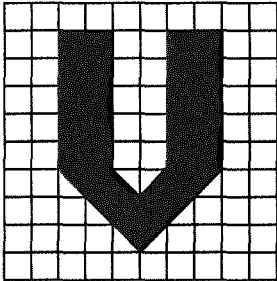

23.

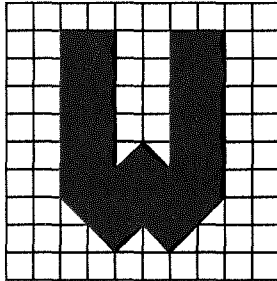

24.

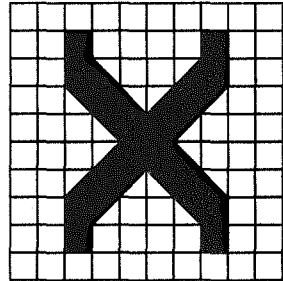

25.

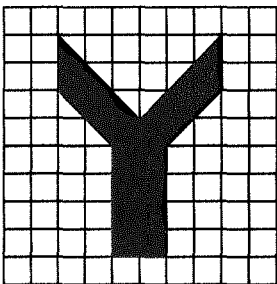

26.

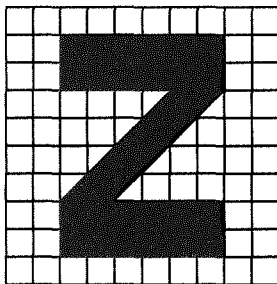

Write your first name: \_\_\_\_\_

Find the area of the letters: \_\_\_\_\_

Write your last name: \_\_\_\_\_

Find the area of the letters: \_\_\_\_\_

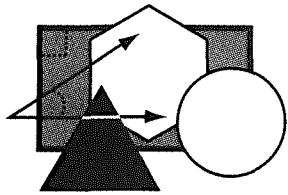

Name \_\_\_\_\_

# GREEN ACRES

An **acre** is an area of land approximately equal to the area of a square measuring 69.6 yd. on each side or 4,840 sq. yd. Most land regions are not regular polygons.

Use the grids to estimate the area of the following shapes.

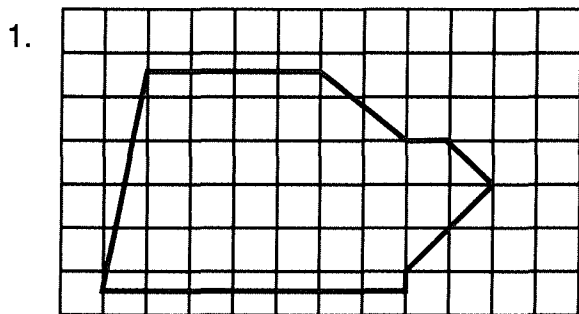

Area = \_\_\_\_\_ sq. yd. or \_\_\_\_\_ acres

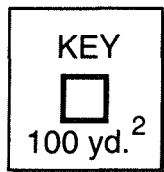
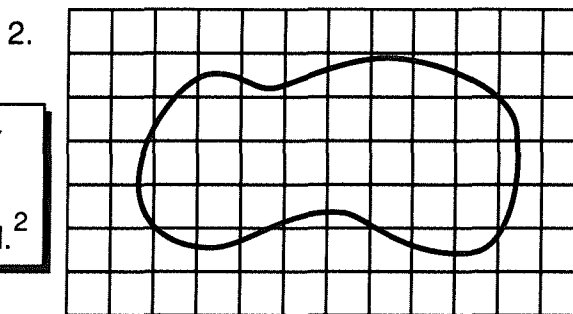

Area = \_\_\_\_\_ sq. yd. or \_\_\_\_\_ acre

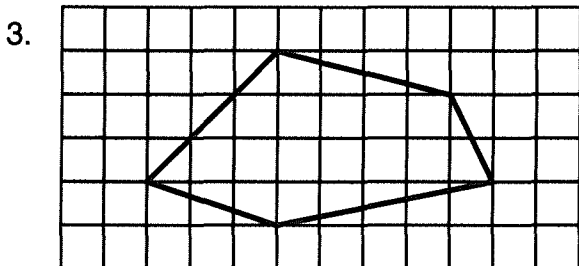

Area = \_\_\_\_\_ sq. yd. or \_\_\_\_\_ acres

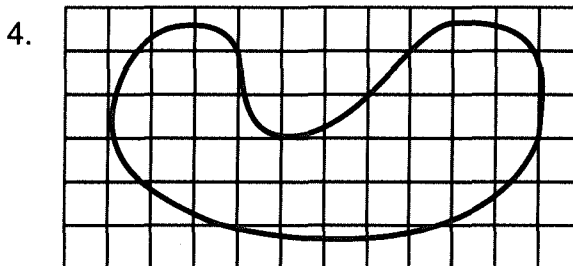

Area = \_\_\_\_\_ sq. yd. or \_\_\_\_\_ acre

Another method is to use the formula for the polygon that resembles the shape.

5. (a) Wyoming resembles a \_\_\_\_\_.  
 (b) The area formula is  $A =$  \_\_\_\_\_.  
 (c) The area of Wyoming = \_\_\_\_\_.

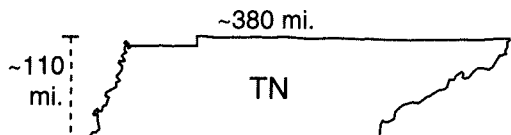
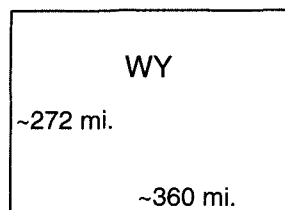

6. (a) Tennessee resembles a \_\_\_\_\_.  
 (b) The area formula is  $A =$  \_\_\_\_\_.  
 (c) The area of Tennessee  $\approx$  \_\_\_\_\_.

7. (a) South Carolina resembles a \_\_\_\_\_.  
 (b) The area formula is  $A =$  \_\_\_\_\_.  
 (c) The area of South Carolina  $\approx$  \_\_\_\_\_.

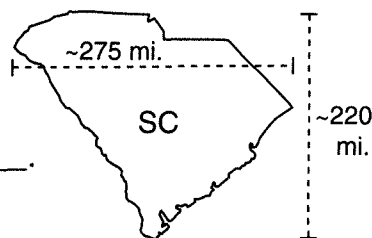

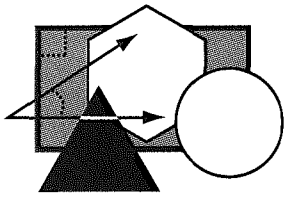

Name \_\_\_\_\_

# TANGRAM

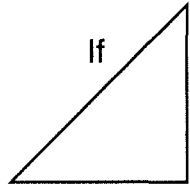

If **I** is one unit of area, find the area of each of the tangram pieces. You may want to copy the triangle and cut it out.

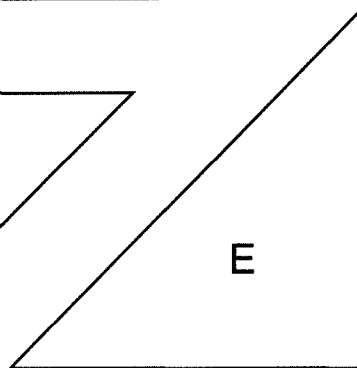
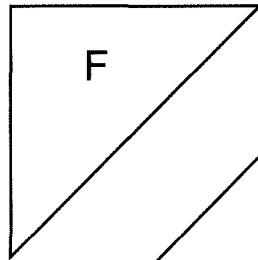
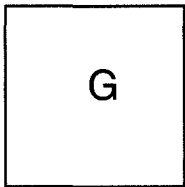
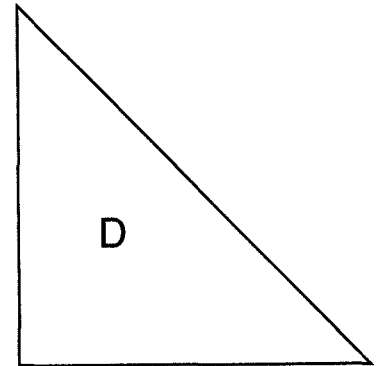
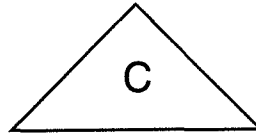
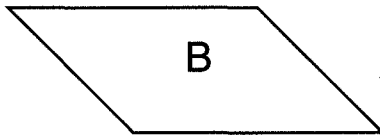
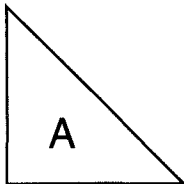

1. A = \_\_\_\_\_ B = \_\_\_\_\_ C = \_\_\_\_\_ D = \_\_\_\_\_ E = \_\_\_\_\_ F = \_\_\_\_\_ G = \_\_\_\_\_

2. What sets of figures have the same area? \_\_\_\_\_  
 \_\_\_\_\_

3. What figures are the same size and shape? \_\_\_\_ & \_\_\_\_      \_\_\_\_ & \_\_\_\_

4. If all seven tangram pieces are used, what is the area of the figure? \_\_\_\_\_

Sketch (include labels) the following shapes using the stated number of pieces.

5. Square using two pieces:

6. Trapezoid using two pieces:

7. Triangle using five pieces:

8. Square using all seven pieces:

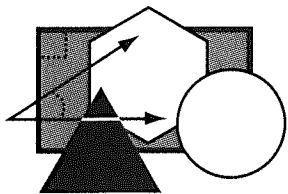

Name \_\_\_\_\_

# TRIANGLES TO TRAPEZOIDS

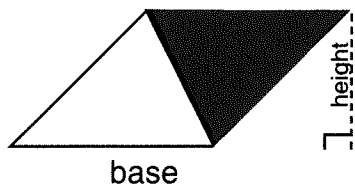

- The area of the triangle is \_\_\_\_\_ the area of the parallelogram.
- The area of a triangle = \_\_\_\_\_ x base x height.

Find the areas of the following triangles.

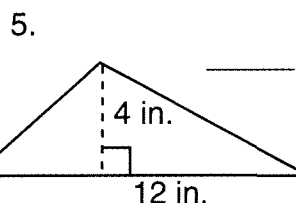
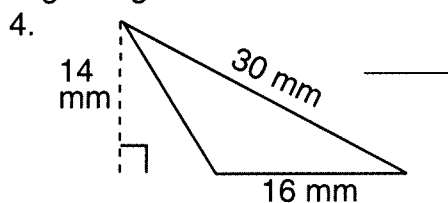
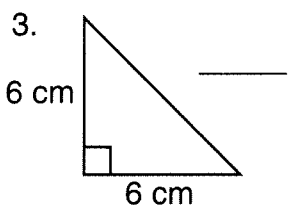

6. Triangle with base equal to 10" and height equal to 10". \_\_\_\_\_

7. Triangle with base equal to 20" and height equal to 20". \_\_\_\_\_

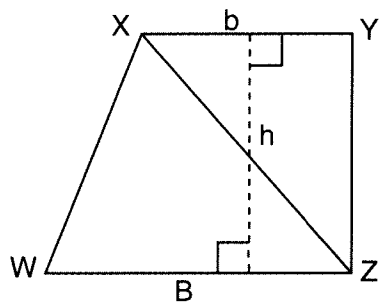

- The area of the trapezoid XYZW equals the area of  $\triangle XYZ$  \_\_\_\_\_ the area of  $\triangle ZWX$ .
- The area of the trapezoid equals  $\frac{1}{2} \times b \times h$  \_\_\_\_\_  $\frac{1}{2} \times B \times h$ .
- Using the distributive property, number 9 becomes the area of a trapezoid =  $\frac{1}{2} (b$  \_\_\_\_\_  $B)h$ .

Find the areas of the trapezoids.

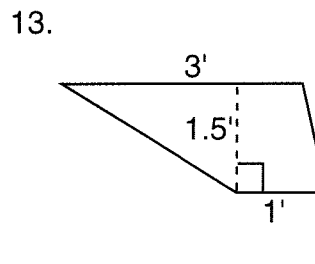
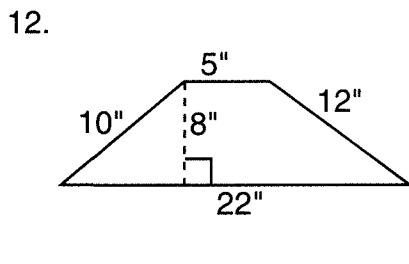
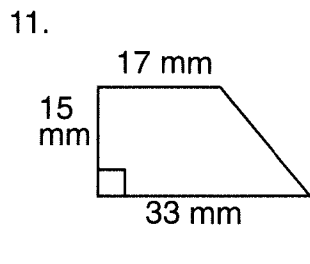

14. Trapezoid with bases 6" and 8" and height 10" \_\_\_\_\_

15. Trapezoid with bases 10" and 8" and height 6" \_\_\_\_\_

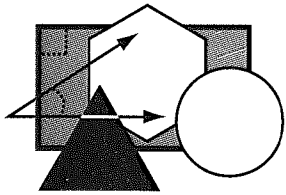

Name \_\_\_\_\_

# COMPOUND AREAS

$\text{Area}_{\text{rectangle}} = l \times w$

$\text{Area}_{\text{triangle}} = \frac{1}{2} b \times h$

$\text{Area}_{\text{circle}} = \pi r^2, \pi = 3.14 \text{ or } \frac{22}{7}$

Divide the figures below into rectangles, triangles, and circles and find the areas.

1.

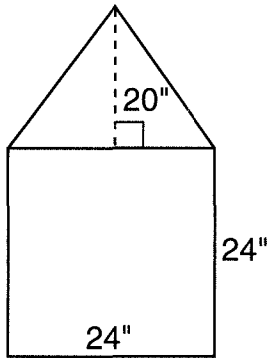

2.

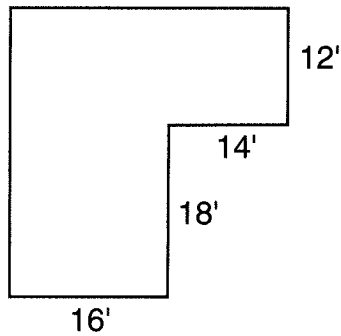

3.

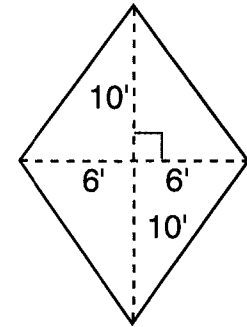

4.

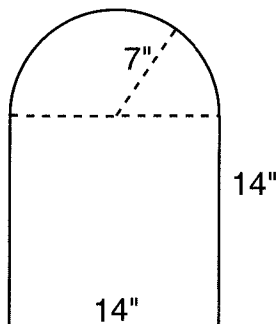

5.

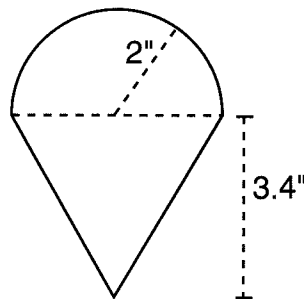

6.

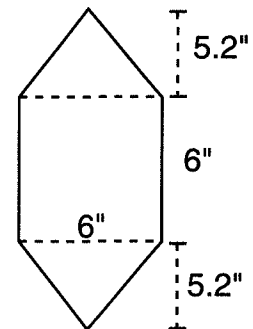

Add or subtract areas to find the area of the shaded regions.

7.

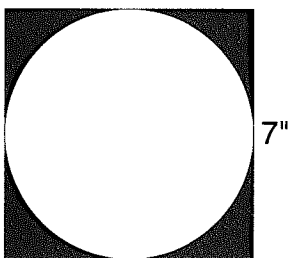

8.

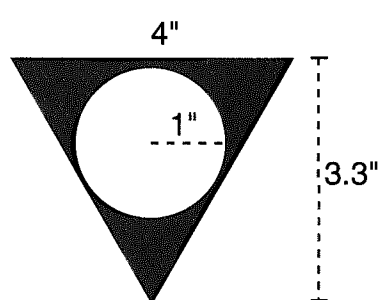

9.

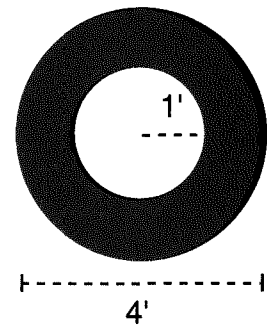

10. How much greater is the area of a four-inch square than a four-inch-diameter circle? \_\_\_\_\_

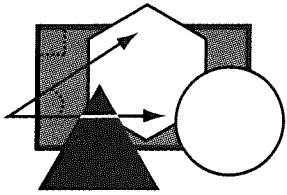

Name \_\_\_\_\_

# NOTHING BUT NET

A **net** is a pattern that can be folded to cover a solid figure. The area of the unfolded net equals the surface area of the solid figure.

Match the net with its solid.

1. \_\_\_\_\_

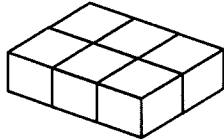

A.

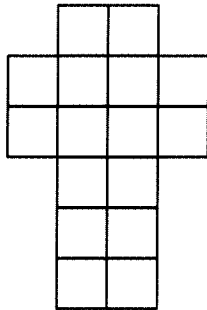

2. \_\_\_\_\_

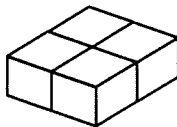

B.

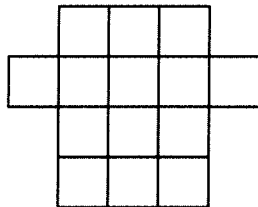

3. \_\_\_\_\_

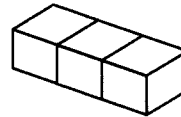

C.

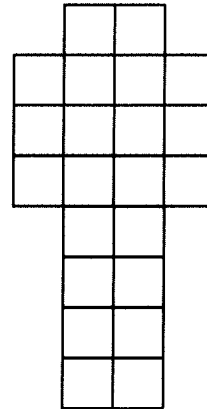

If each square represents  $1 \text{ cm}^2$ , find the surface area of each solid.

4. Area #1 = \_\_\_\_\_  $\text{cm}^2$

5. Area #2 = \_\_\_\_\_  $\text{cm}^2$

6. Area #3 = \_\_\_\_\_  $\text{cm}^2$

7. Which pattern is a net for a cube 1 cm on an edge? \_\_\_\_\_

A.

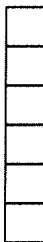

B.



C.

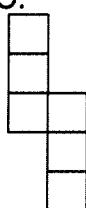

D.

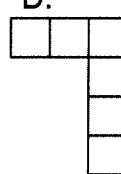

8. On the grid draw a net for the rectangular prism shown and calculate its surface area.

Net:

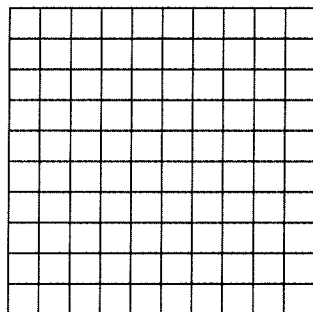
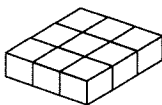

Area:

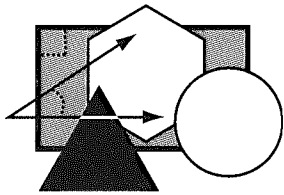

Name \_\_\_\_\_

# "GREAT" AREAS

The surface area of a pyramid is the sum of the area of its base and the areas of the lateral faces.

The number of lateral (sides) faces of a pyramid is determined by the shape of its base. A square pyramid has a square base and four triangular faces.

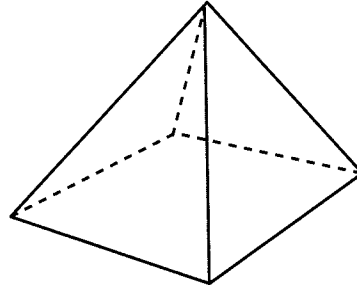

Square Pyramid

Use the area formulas  $A_{\text{square}} = \text{side} \times \text{side}$  and  $A_{\text{triangle}} = \frac{1}{2} \text{base} \times \text{height}$ .

1.-4.

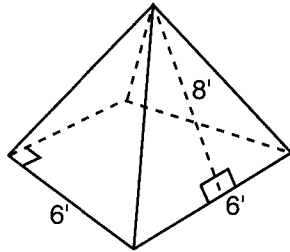

1. Area of one triangular face: \_\_\_\_\_

2. Combined area of four faces: \_\_\_\_\_

3. Area of base: \_\_\_\_\_

4. Total surface area: \_\_\_\_\_

5.-8.

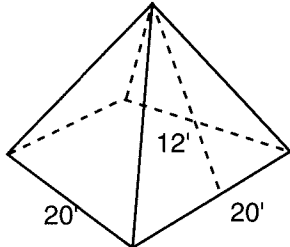

5. Area of one triangular face: \_\_\_\_\_

6. Combined area of four faces: \_\_\_\_\_

7. Area of base: \_\_\_\_\_

8. Total surface area: \_\_\_\_\_

The Great Pyramid near Cairo, Egypt, is a square pyramid. It is more than 4,500 years old and at one time contained the mummy and treasures of Khufu, a powerful Egyptian pharaoh. The height of each side was 612 feet, and the base was 756 feet on each side.

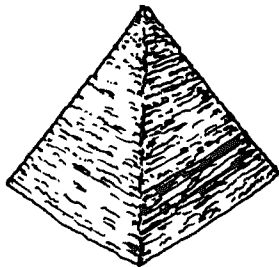

9. Area of one triangular face: \_\_\_\_\_

10. Combined area of four faces: \_\_\_\_\_

11. Area of base: \_\_\_\_\_

12. Total surface area: \_\_\_\_\_

The Great Pyramid has settled. Each side is now 22 ft. shorter, and the base is approximately 734 ft. on each side. Find the area of the visible part of the Great Pyramid.

13. Area of one face: \_\_\_\_\_

14. Combined area of four faces: \_\_\_\_\_

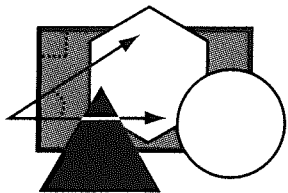

Name \_\_\_\_\_

# TERMS OF ENCIRCLEMENT

Use the following definitions to identify parts of the circle:

**circle**—set of points a given distance (the radius) from a given point (center)

**center**—the point used to determine a circle

**chord**—any line segment that joins two points of a circle

**diameter**—a chord that passes through the center

**radius**—any line segment from the center to a point on the circle

**tangent**—a line that intersects a circle at only one point

**semicircle**—half a circle, named by three points: endpoints and a point between the endpoints

**minor arc**—a section of a circle less than a semicircle, named by its endpoints

**major arc**—a section of a circle greater than a semicircle, named by three points: an endpoint, a point between the endpoints, and the other endpoint

**central angle**—any angle with a vertex at the center of a circle

**inscribed angle**—any angle with a vertex on a circle and rays that intersect the circle

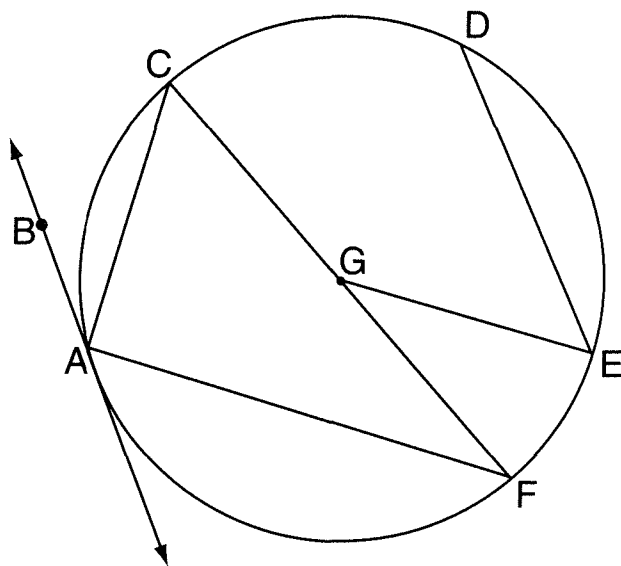

Name each of the following for the diagram above:

1. center \_\_\_\_\_
2. chords \_\_\_\_\_
3. diameters \_\_\_\_\_
4. radii \_\_\_\_\_
5. tangent \_\_\_\_\_
6. semicircles \_\_\_\_\_
7. minor arcs \_\_\_\_\_
8. major arcs \_\_\_\_\_
9. central angles \_\_\_\_\_
10. inscribed angle \_\_\_\_\_

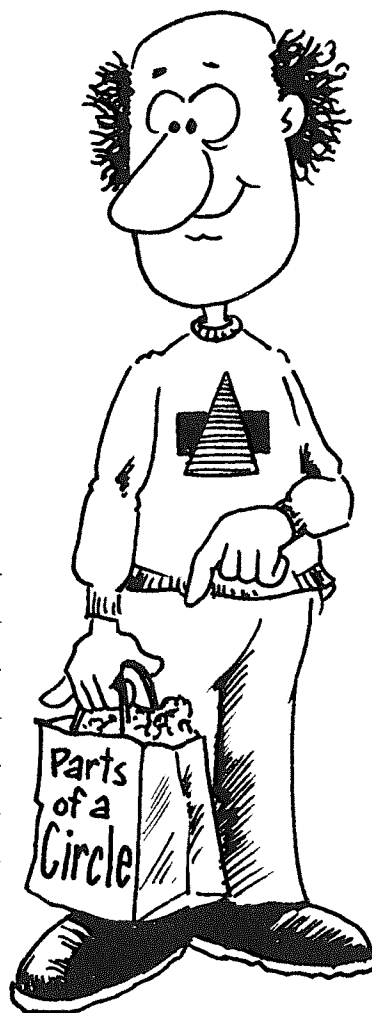

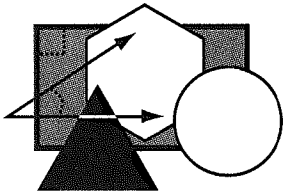

Name \_\_\_\_\_

# ARC TO ARCTURUS

An **arc** is part of a circle. The degree measure of an arc is the measure of its **central angle**. A central angle cuts a circle into two arcs. The arc less than a semicircle is the **minor arc** and is named by its endpoints,  $\widehat{AB}$ . The arc greater than a semicircle is the **major arc**. A third point is needed to name the major arc,  $\widehat{ACB}$ .

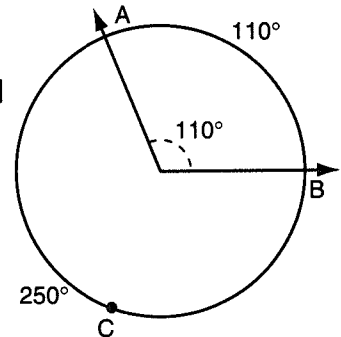

Use a protractor to find the arc degree measure associated with each sector of the circle graph.

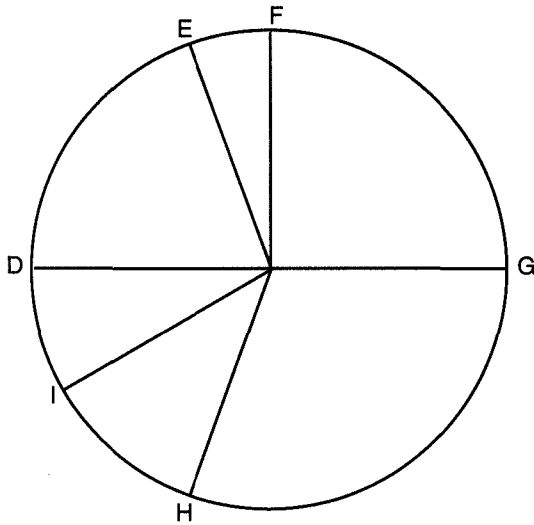

1.  $\widehat{DE}$  \_\_\_\_\_
2.  $\widehat{EF}$  \_\_\_\_\_
3.  $\widehat{FG}$  \_\_\_\_\_
4.  $\widehat{GH}$  \_\_\_\_\_
5.  $\widehat{HI}$  \_\_\_\_\_
6.  $\widehat{ID}$  \_\_\_\_\_
7. The sum of the answers to #1–#6 is \_\_\_\_\_.

An **inscribed angle** has a vertex on the circle, and both rays intersect the circle. The inscribed angle XYZ determines the same arc as the central angle XWZ.

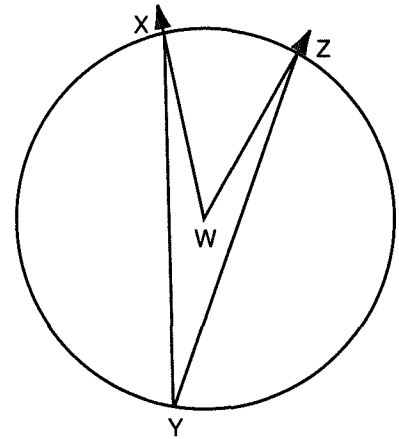

8. Measure angle XYZ. \_\_\_\_\_
9. How does angle XYZ compare to angle XWZ? \_\_\_\_\_
10. If the inscribed angle PQR = 40°, what is the measure of minor arc PR? \_\_\_\_\_  
major arc PQR? \_\_\_\_\_

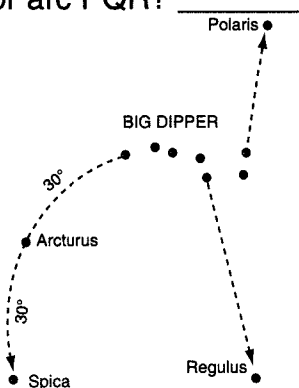

In the night sky, one can locate the star Arcturus by following the arc of the handle of the Big Dipper 30°. Another 30° arc locates the star Spica.

11. If the arc distance from the Big Dipper to Arcturus measures 2 cm on a picture, the full circle would have a circumference of \_\_\_\_\_ cm.
12. The Big Dipper to Spica arc is what part of a full circle? \_\_\_\_\_

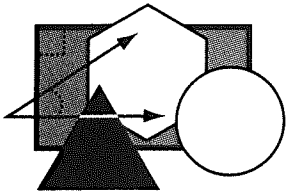

Name \_\_\_\_\_

# AROUND AND AROUND WE GO

The perimeter of a circle is called its **circumference**. *Pi* is the ratio of the circumference (C) of a circle to its diameter (d):  $\pi = C/d$  or  $C = \pi d$ .  $\pi$  equals approximately 3.14 or  $22/7$ .

Find the circumference or diameter for each circle. Remember: diameter equals 2 radii.

1.  $C =$  \_\_\_\_\_

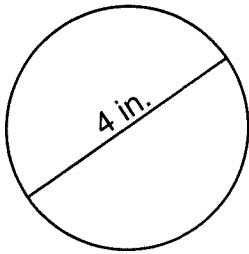

2.  $d =$  \_\_\_\_\_  $C =$  \_\_\_\_\_

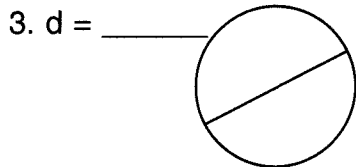
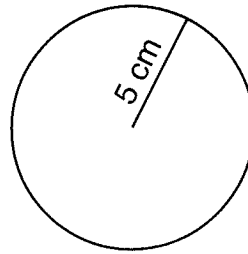

$C \sim 9 \frac{3}{4}$  in.

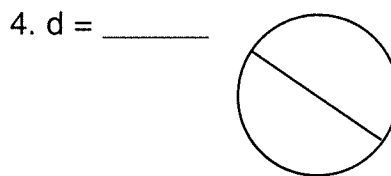

$C \sim 21.98$  cm

Complete the table:

	Radius	Diameter	Circumference
5.	1 in.		
6.		6 cm	
7.			22 in.
8.			6.28 cm

Consider a tennis ball can that holds three tennis balls. Does the height of the can appear to be greater or less than the distance around the can? \_\_\_\_\_

9. If a tennis ball has a diameter of 2.5", the height of the can is at least \_\_\_\_\_.

10. The distance around the can is at least \_\_\_\_\_.

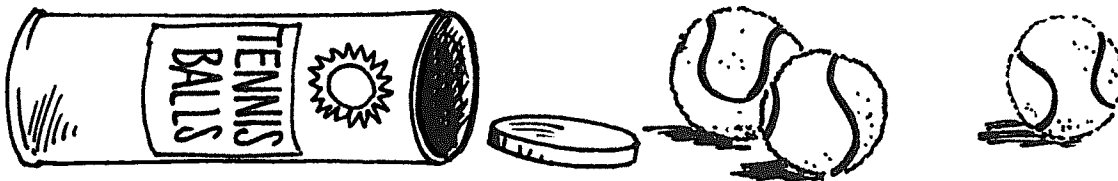

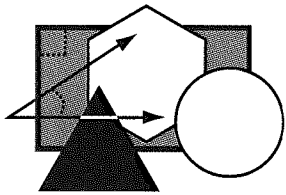

Name \_\_\_\_\_

# PIZZA PI

Consider a 16-slice circular pizza with the slices rearranged to form a “rectangular” shape. The area of the rectangle equals  $\pi r \times r$  or  $\pi r^2$ . Let  $\pi = 3.14$ .

$$A_{\text{circle}} = \pi r^2$$

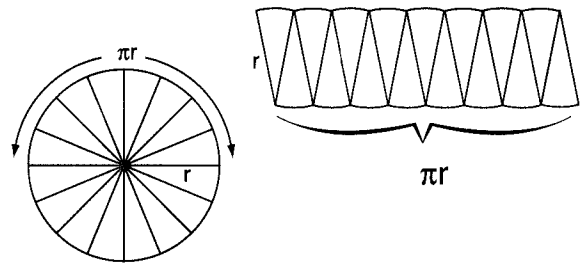

- Find the area of a 12-inch pizza.  
(A 12-inch pizza has a 12-inch diameter.)
- Find the area of a 16-inch pizza.
- A 12-inch pizza costs \$8.99. Find the cost/sq. in. to the nearest cent.
- A 16-inch pizza costs \$13.99. Find the cost/sq. in. to the nearest cent.
- Is the 12-inch or 16-inch pizza the better buy?
- Terry ate  $\frac{1}{4}$  of a 14-inch pizza. How much pizza was left?
- Patty’s Pizza Parlor is converting to rectangular-shaped pizzas. How long would an 8-inch-wide pan have to be to hold the same amount of pizza as a 12-inch round pizza?
- Petey’s Pizza offers two 10-inch pizzas for the same price as the 16-inch pizza. Which is the better buy?
- One hundred 1-inch pepperoni slices are placed on a 12-inch pizza. If none of the slices overlap, how much pizza (area) does not have pepperoni on it?
- As sponsor of a car rally, Cal offered “tire-shaped” pizzas. The pizzas had an outside radius of 8 inches and the hole had a 4-inch radius. What is the area of one pizza?

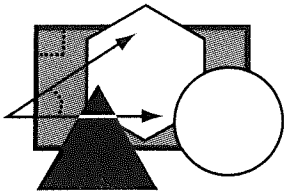

Name \_\_\_\_\_

# FILL IT UP

The **volume** of a solid is the number of cubic units needed to fill a figure.



If  represents 1 cubic unit, then the rectangular prism 4 units x 3 units x 2 units would hold 24 cubic units—1 layer would contain 4 x 3 cubic units, and the solid would hold two layers, 4 x 3 x 2 cubic units.

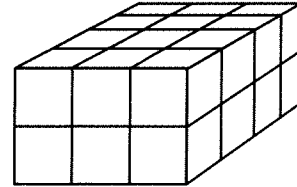

$$V_{\text{rect. prism}} = \text{length} \times \text{width} \times \text{height} = \text{Area}_{\text{base}} \times \text{height}$$

Find the volume of each solid.

1.

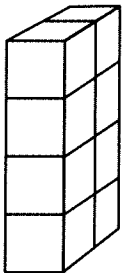

2.

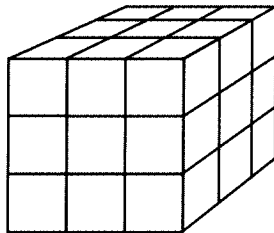

3.

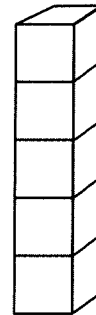

Complete the table.

	Length	Width	Height	Volume
4.	1 in.	2 in.	3 in.	
5.	2 in.	4 in.		48 in. <sup>3</sup>
6.	3 in.		9 in.	162 in. <sup>3</sup>
7.		4 cm	5 cm	20 cm <sup>3</sup>
8.	9 cm	12 cm	15 cm	

9. How do the dimensions of #5 compare to the dimensions of #4? \_\_\_\_\_
10. How does the volume of #5 compare to the volume of #4? \_\_\_\_\_
11. How do the dimensions of #6 compare to the dimensions of #4? \_\_\_\_\_
12. How does the volume of #6 compare to the volume of #4? \_\_\_\_\_

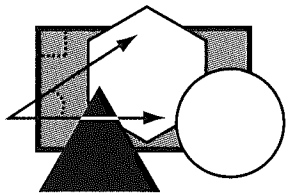

Name \_\_\_\_\_

# TO THE POINT

**Pyramids** and **cones** are solids with one base and a major vertex. The area (A) of a two-dimensional triangle equals  $\frac{1}{2} \times \text{base} \times \text{height}$ . The volume (V) of a three-dimensional pyramid is  $\frac{1}{3} \times \text{area of the base (B)} \times \text{height}$ .

1. Compare  $A = \frac{1}{2} bh$  and  $V = \frac{1}{3} Bh$ .

2. Find the volume of a square pyramid 10 ft. high with a base 6 ft. on a side.

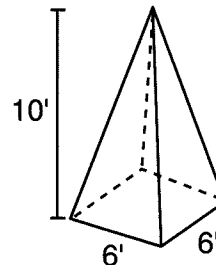

3. Find the volume of a square pyramid 6 ft. high with a base 10 ft. on a side.

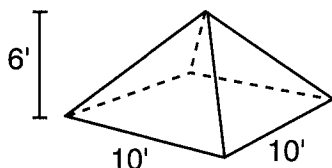

4. Find the volume of a triangular pyramid 10 ft. high with a base of 6 ft. and height of 8 ft.

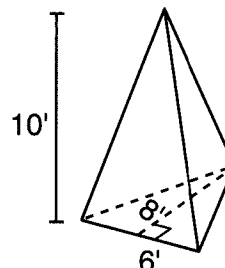

A cone has one circular base and a curved surface that connects the base to one vertex  $V = \frac{1}{3} \times \text{area of the base} \times \text{height}$  or  $\frac{1}{3} \times \pi r^2 \times h$ . Let  $\pi = \frac{22}{7}$ .

5. A road salt storage building is cone-shaped. Its height is 21 ft. and its base has a radius of 14 ft. How many cu. ft. of salt will it hold? \_\_\_\_\_

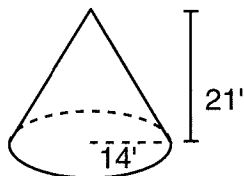

6. A truck has a trailer that measures 16 ft. long, 6 ft. wide, and 5 ft. high. Find the volume of the trailer. \_\_\_\_\_

How many trailer loads will fill the storage building in #5? \_\_\_\_\_

7. An ice-cream cone has a height of 7 cm and a base radius of 3 cm. Find the volume of the cone. \_\_\_\_\_

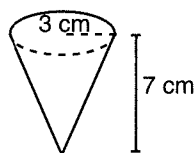

8. The volume of a sphere  $= \frac{4}{3} \times \pi r^3$ . Find the volume of a 3-cm (radius) sphere of ice cream. \_\_\_\_\_

9. If the ice cream melts, will it overflow the cone in #7? \_\_\_\_\_

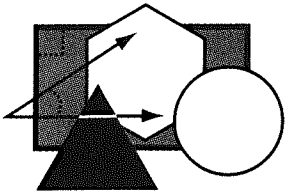

Name \_\_\_\_\_

# ALL POINTS BULLETIN

A **coordinate grid** is a system for locating points. The grid is divided into four **quadrants** by two **axes** that intersect at the **origin**. A point is named by an **ordered pair**. The first number is the distance along the x-axis, and the second number is the distance along the y-axis.

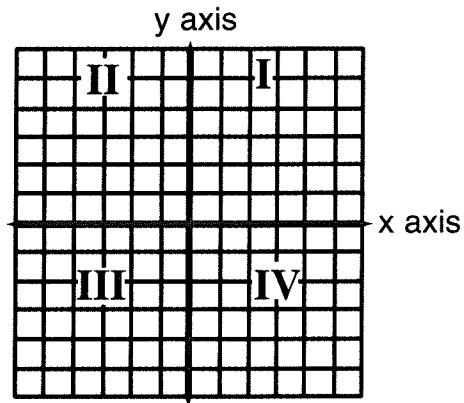

Plot the points.

- 1. A (5, -1)
- 2. B (-3, -5)
- 3. C (0, 3)
- 4. D (-2, 4)
- 5. E (1, 1)
- 6. F (-5, 0)

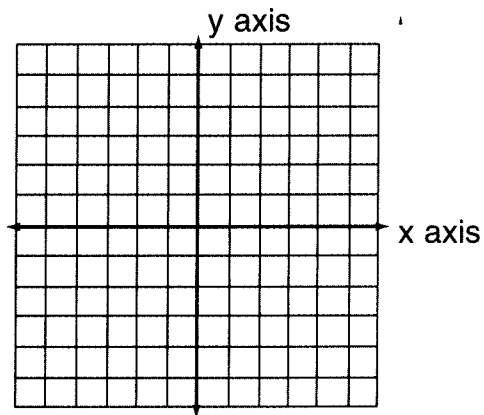

Give the quadrant for each point.

- 7. (4, 1) \_\_\_\_\_
- 8. (-2, -5) \_\_\_\_\_
- 9. (-1, 2) \_\_\_\_\_
- 10. (5, -2) \_\_\_\_\_

Start at the \*, move clockwise, and state the ordered pair for each point •.

\*(-3,0)

- 11. \_\_\_\_\_
- 12. \_\_\_\_\_
- 13. \_\_\_\_\_
- 14. \_\_\_\_\_
- 15. \_\_\_\_\_
- 16. \_\_\_\_\_
- 17. \_\_\_\_\_
- 18. \_\_\_\_\_
- 19. \_\_\_\_\_
- 20. \_\_\_\_\_

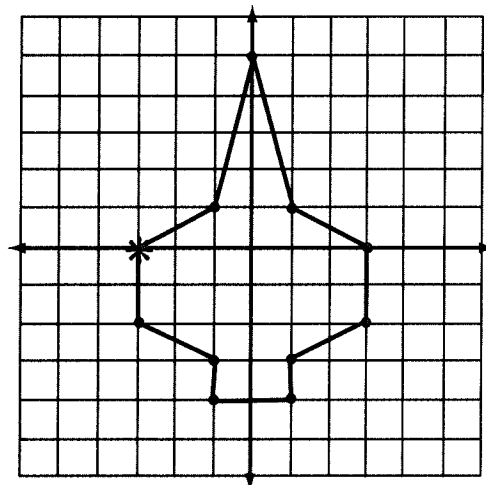

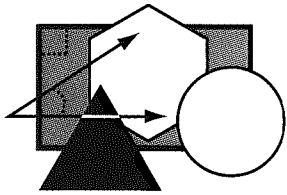

Name \_\_\_\_\_

# THE RISE AND THE RUN

**Slope** is the ratio of rise/run and indicates the steepness of the graph of a line. The **rise** is the vertical change and the **run** is the horizontal change.

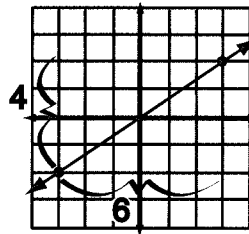

Slope =  $\frac{4}{6}$  or  $\frac{2}{3}$

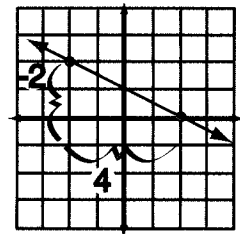

Slope =  $-\frac{2}{4}$  or  $-\frac{1}{2}$

Find the slope of each line.

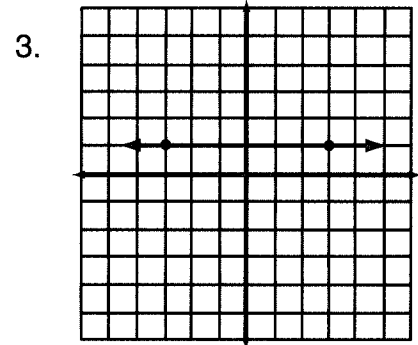
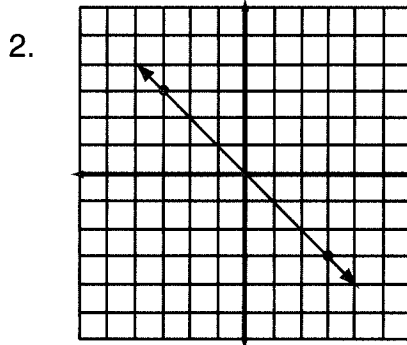
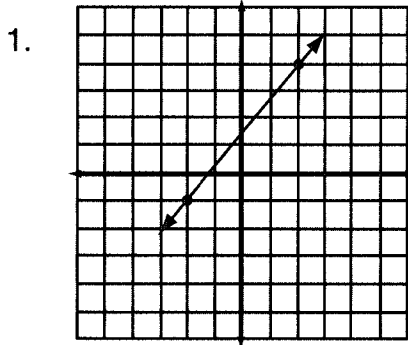

4. If a line rises from left to right, what can be said of the slope? \_\_\_\_\_

5. If a line falls from left to right, what can be said of the slope? \_\_\_\_\_

Slope can be determined from the coordinates of two points on the line.

(2, 3) and (4, 9)  
 $\frac{\text{rise}}{\text{run}} = \frac{9 - 3}{4 - 2} = \frac{6}{2} = 3$

(6, 1) and (-2, 4)  
 $\frac{\text{rise}}{\text{run}} = \frac{4 - 1}{-2 - 6} = \frac{3}{-8}$

Find the slope of the line passing through the two points.

6. (0, 2) and (3, 4)

7. (-1, 3) and (2, 1)

8. (2, -4) and (1, 1)

9. Graph the points from #6. Draw the line. Does it rise or fall? \_\_\_\_\_

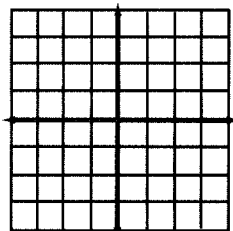

10. Graph the points from #7. Draw the line. Does it rise or fall? \_\_\_\_\_

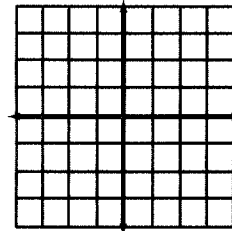

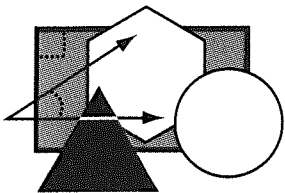

Name \_\_\_\_\_

# GRAPH IT!

Use the table of values to plot points. Connect the points.

1.

x	y
-2	-5
-1	-3
0	-1
1	1
2	3

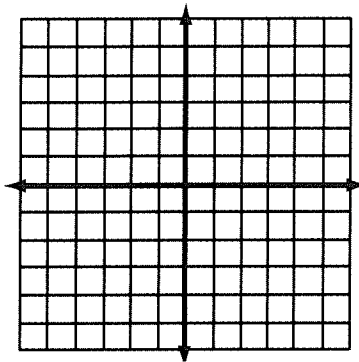

2.

x	y
-2	3
-1	2
0	1
1	0
2	-1

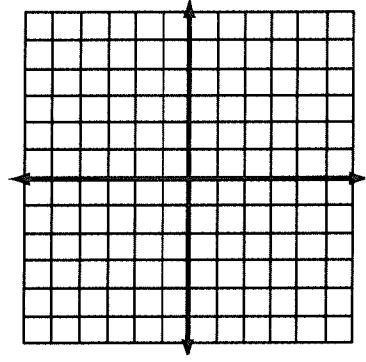

3. In #1, when the x-value changes by +1, the y-value changes by \_\_\_\_\_.

4. In #2, when the x-value changes by +1, the y-value changes by \_\_\_\_\_.

Use the table of values to plot points. Connect the points.

5.

x	y
-2	4
-1	1
0	0
1	1
2	4

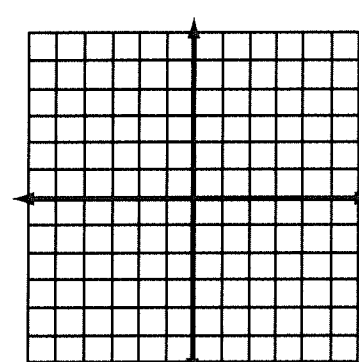

6.

x	y
-2	0
0	2
2	0
0	-2

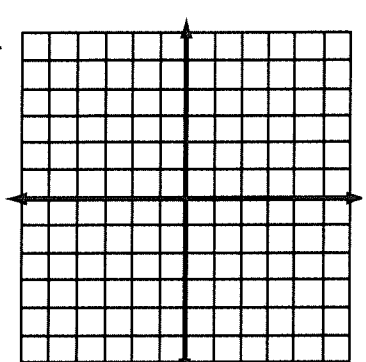

7. In #5, whether x is positive or negative, y is \_\_\_\_\_.

8. In #6, the graph is not a function because when  $x = 0$ , there are \_\_\_\_\_ y-values.

9. Give the number of the table of values (1, 2, 5, or 6) corresponding to each equation and describe the "shape" of the graph.

A.  $y = -x + 1$  \_\_\_\_\_

B.  $x^2 + y^2 = 4$  \_\_\_\_\_

C.  $y = 2x - 1$  \_\_\_\_\_

D.  $y = x^2$  \_\_\_\_\_

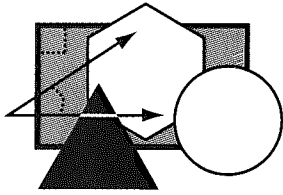

Name \_\_\_\_\_

# INTERESTING INTERSECTIONS

The **points of intersection** of figures are the points that the figures have in common.  
Examples:

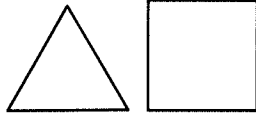

No points

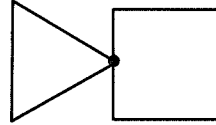

One point

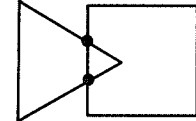

Two points

Use two circles to show the indicated points of intersection.

1. 0 points

2. 1 point

3. 2 points

Use two angles to show the indicated points of intersection.

4. 0 points

5. 1 point

6. 2 points

7. 3 points

8. 4 points

Use two triangles to show the indicated points of intersection.

9. 0 points

10. 1 point

11. 2 points

12. 3 points

13. 4 points

14. 5 points

15. 6 points

The intersection of two sets is the set of elements they have in common.  
Name the intersection of the following sets.

16. {even numbers} and {prime numbers} \_\_\_\_\_

17. {months} and {words ending in "y"} \_\_\_\_\_

18. {days} and {words beginning with "t"} \_\_\_\_\_

19. {negative numbers} and {positive numbers} \_\_\_\_\_

20. {nonnegative numbers} and {nonpositive numbers} \_\_\_\_\_

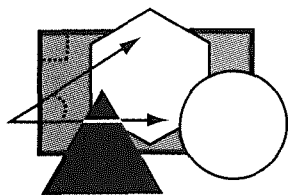

# ONE-SIDED PAPER

Cut along the lines to make four strips one-inch wide.

**Strip 1:** Tape the ends together to make a loop. Start at the \* and run a pencil line around the loop back to the \*.

1. How many sides does the loop have?
2. Is the pencil line on all sides?

**Strip 2:** Twist one end a half-turn and tape the edges together (the "back" of one end is taped to the "front" of the other end). This loop is called a **Möbius strip**. Start at the \* and run a pencil line around the loop back to the \*.

3. How many sides does the loop have?
4. Is the pencil line on all sides?

**Strip 3:** Make a Möbius strip (see Strip 2). Cut the loop down the middle.

5. How many loops do you have?
6. Describe the loops.

**Strip 4:** Make a Möbius strip (see Strip 2). Cut the loop one third of the distance from the edge.

7. How many loops do you have?
8. Describe the loops.

**Extension:** Try other combinations of twists. Draw pencil lines, make cuts, and describe the results.

1\*

2\*

3

4

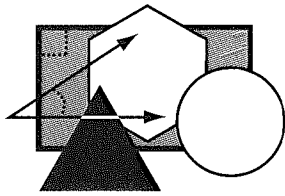

Name \_\_\_\_\_

# FOLD, SPINDLE, OR DRAW

Several geometric shapes can be drawn or folded using simple materials.

**Circle:** thumbtack, string, cardboard, pencil

- Step 1. Place a thumbtack in the center of a piece of cardboard.
2. Tie a string in a loop that when pulled taut is the length of the radius.
3. Place the loop around the thumbtack and pull the loop taut with the pencil point.
4. Draw the circle keeping the string loop taut.

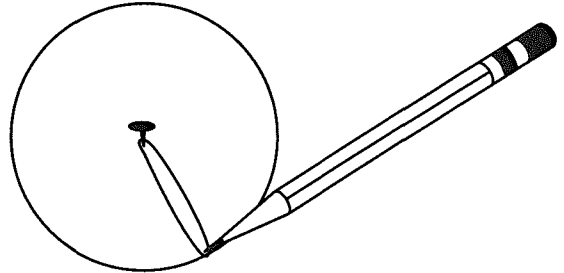

Why: A circle is the set of points a given distance (the radius) from a given point (the center).

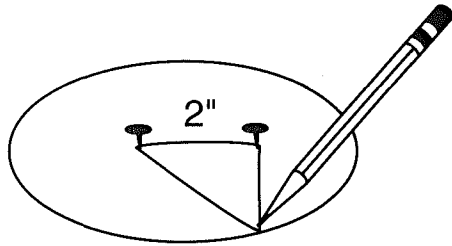

**Ellipse:** two thumbtacks, string, cardboard, pencil

- Step 1. Place two thumbtacks two inches apart on a piece of cardboard (foci).
2. Tie a string in a loop that when pulled taut is four inches in length.
3. Place the loop around the thumbtacks. Keep the loop taut with the pencil point.
4. Draw an ellipse keeping the string loop taut.

Why: An ellipse is the set of points in which the sum of the distances from the foci is a constant.

**Ellipse:** plain paper or wax paper, ruler, pencil

- Step 1. Draw a three-inch radius circle. Mark the center.
2. Draw a point A two inches from the center.
3. Fold and crease the paper so a point on the circle touches point A.
4. Make 30 to 40 such folds around the circle.

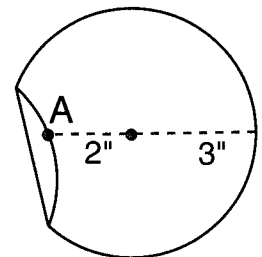

Why: The sum of the distance from the fold to the center and to point A is constant.

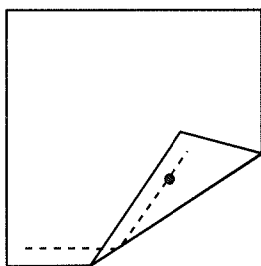

**Parabola:** plain paper or wax paper, ruler, paper

- Step 1. Draw a point (focus).
2. Draw a line parallel to bottom of paper.
3. Fold and crease the paper 30 to 40 times so the line touches the point.



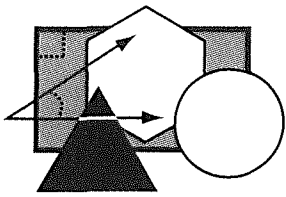





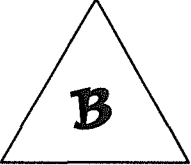

Why: A parabola is the set of points equidistant from a point and a line.

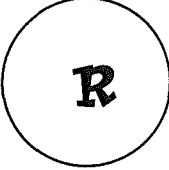

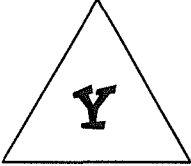
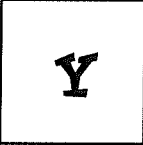
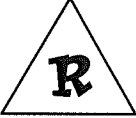
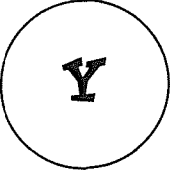
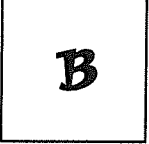
Name \_\_\_\_\_

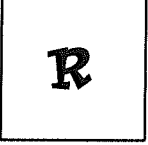
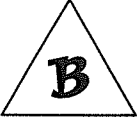
# ATTRIBUTES WITH AN ATTITUDE

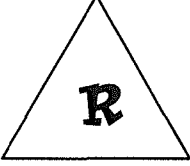
Mark the path from Start to Finish showing a change in exactly two attributes—size (small or large), shape (triangle, square, or circle), or color (B, R, and Y). Move horizontally or vertically, not diagonally.

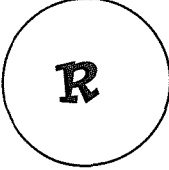
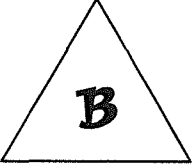
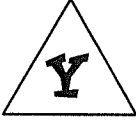
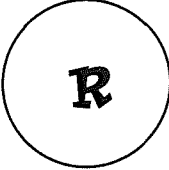
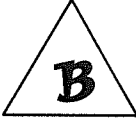
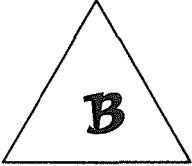
				
				
				
				
 <b>START</b>				 <b>FINISH</b>

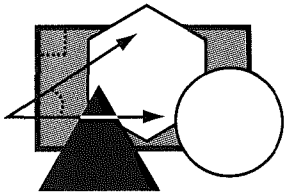

Name \_\_\_\_\_

# A MOVING EXPERIENCE

A **transformation** is a rule for moving a figure to a new location. **Slides** (translations), **turns** (rotations), and **flips** (reflections) maintain the figure size.

Ex.

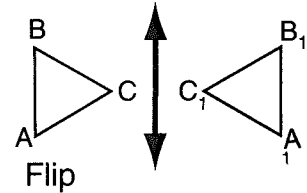
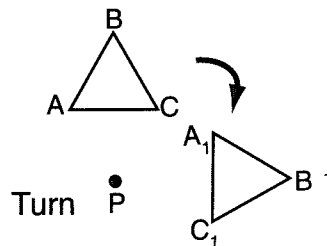
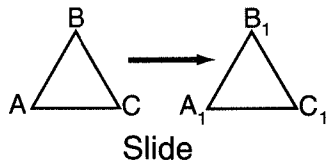

Use the grids to show the indicated transformations. Label corresponding points.

1. Slide 3 units right and 2 units down.

2. Turn  $90^\circ$  clockwise about P.

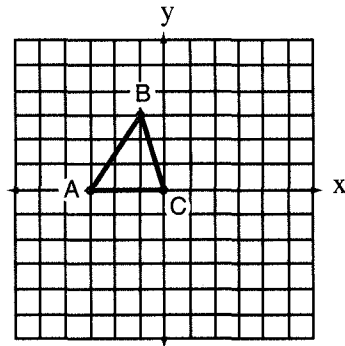

3. Flip over the y-axis.

4. Slide 6 units left and 4 units up.

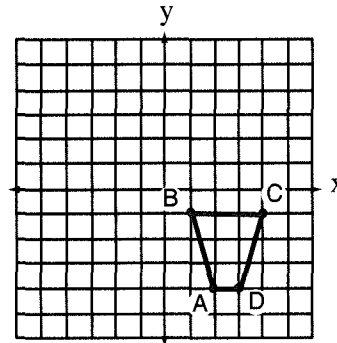
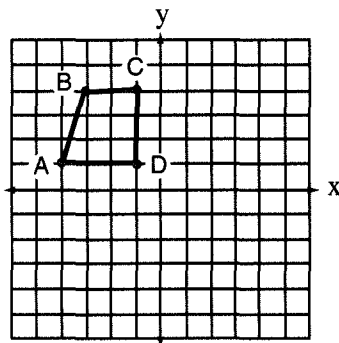

5. Turn  $180^\circ$  counterclockwise about P.

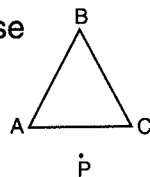

6. Flip over the x-axis.

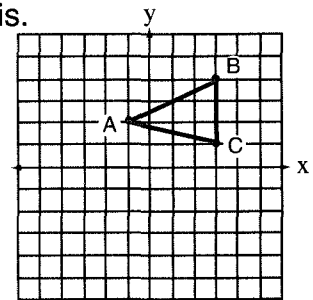

Bonus: Describe #5 in terms of flips. \_\_\_\_\_

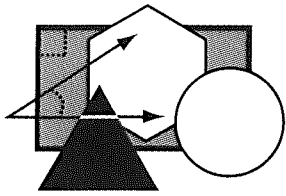

Name \_\_\_\_\_

# POINT OF VIEW

Two-dimensional drawings can be used to show top, front, and side views of three-dimensional objects.

Ex.

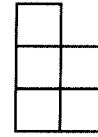
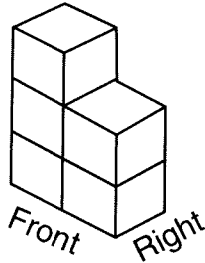

Front

Right

Top

Front

Right Side

Use the grid to draw the top, front, and right side views of the given figure.

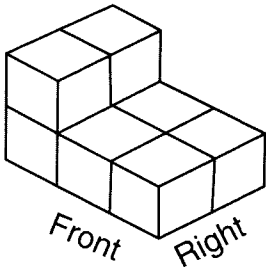

Front

Right

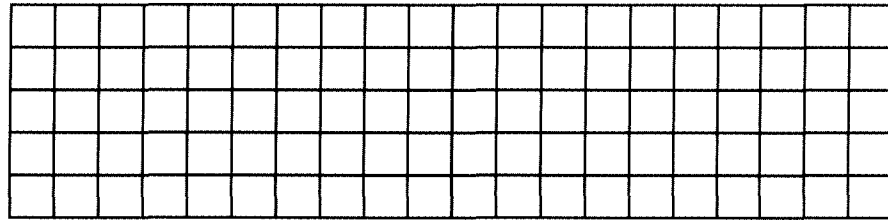

1. Top

2. Front

3. Right Side

Use the grids to draw the figures based on the top, front, and side views.

4.



Top

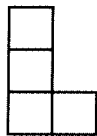

Front



Right Side

4.

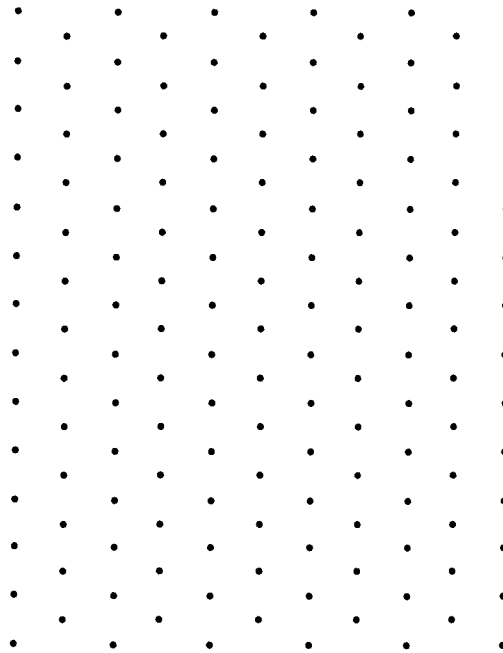

5.

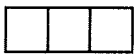

Top

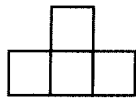

Front



Right Side

5.



6. Draw a figure that has identical top, front, and side views. \_\_\_\_\_

7. What figure would have triangular front and side views, and a square top view? \_\_\_\_\_

circular top view? \_\_\_\_\_

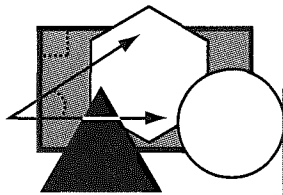

Name \_\_\_\_\_

# NETWORK NEWS

A **network** is a graphical system of points called **vertices**. The vertices are connected by segments called **edges**. The number of edges that meet at a vertex is the **degree** of a vertex. A network is **connected** if it is possible to travel from any vertex to any other vertex along an edge. A network is **traceable** if one can start at a vertex and travel to all other vertices along each edge exactly once.

For each network, state the number of vertices (V), and the number of edges (E).

1.

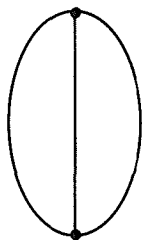

V \_\_\_ E \_\_\_

2.

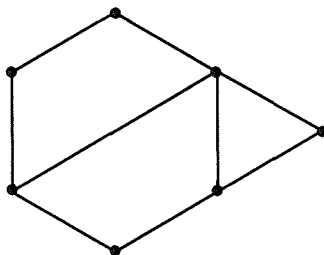

V \_\_\_ E \_\_\_

3.

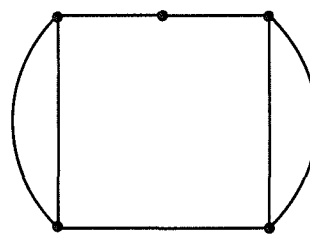

V \_\_\_ E \_\_\_

To trace a network, you must be able to “enter” and “leave” each vertex—an even degree—except perhaps the starting and ending vertices. Therefore, a network is **traceable** if it has no more than two vertices with an odd degree.

Next to each vertex of the given networks, write the degree. If the network is traceable, list the order of the vertices for a possible trace.

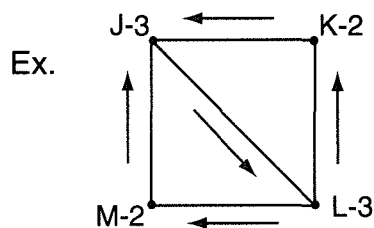

Trace:  
L, M, J, L, K, J

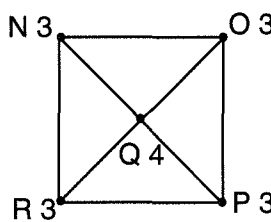

Trace: Not possible  
> 2 vertices with odd degree

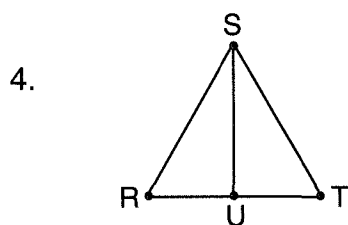

Trace:

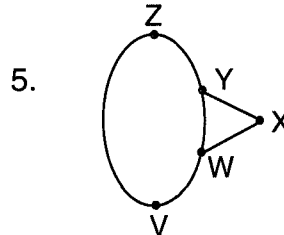

Trace:

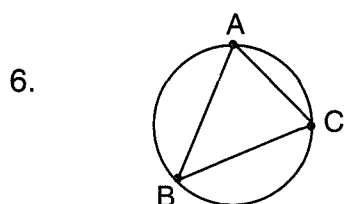

Trace:

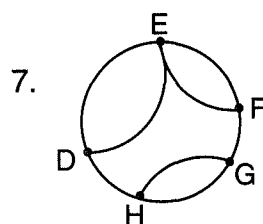

Trace:

acute angle	acute triangle	adjacent angles
altitude of a triangle	angle	chord of a circle
circle and radius	complementary angles	circumscribed triangle
concentric circles	cone	congruent triangles
right cylinder	equilateral triangle	regular hexagon
irregular pentagon	hypotenuse	kite
major arc	obtuse angle	opposite rays
parallel lines	parallelogram	perpendicular lines
prism	regular pyramid	rectangle
right triangle and legs	secant of a circle	similar triangles
point	line	angle
space	sphere	straight angle
supplementary angles	tangent to a circle	trapezoid
two lines and a transversal	vertical angles	alternate interior angles
corresponding angles	apothem	axes
quadrilateral	square inscribed in a circle	exterior angle of a triangle

You can create many types of designs using only straight lines. Here are two line designs and the steps for creating each one.

**The Astrid**

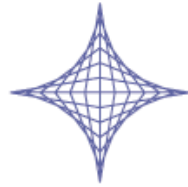

**The 8-Pointed Star**



**The Astrid**

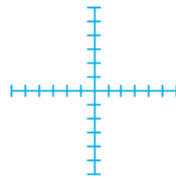

Step 1

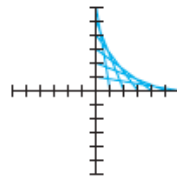

Step 2

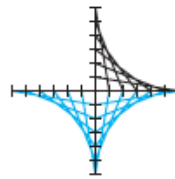

Step 3

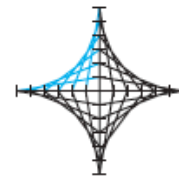

Step 4

**The 8-Pointed Star**



Step 1



Step 2



Step 3



Step 4

## EXERCISES

1. What are the classical construction tools of geometry?
2. Create a line design from this lesson. Color your design.
3. Each of these line designs uses straight lines only. Select one design and re-create it on a sheet of paper. 

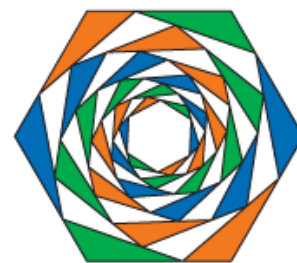
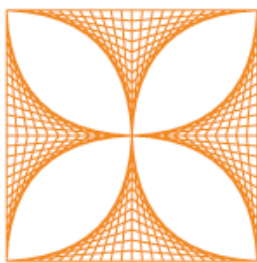

4. Describe the symmetries of the three designs in Exercise 3. For the third design, does color matter?

LESSON

0.3

# Circle Designs

People have always been fascinated by circles. Circles are used in the design of mosaics, baskets, and ceramics, as well as in the architectural design of buildings.

*It's where we go, and what we do when we get there, that tells us who we are.*

JOYCE CAROL OATES



Chinese pottery



Palestinian cloth

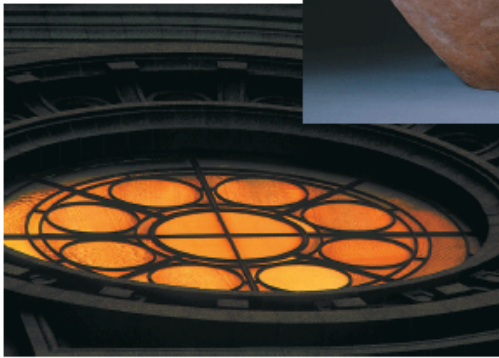

Circular window

You can make circle designs with a compass as your primary tool. For example, here is a design you can make on a square dot grid.

Begin with a 7-by-9 square dot grid. Construct three rows of four circles.

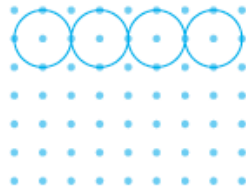

Step 1

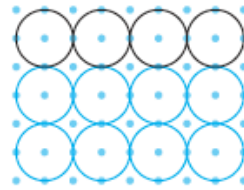

Step 2

Construct two rows of three circles using the points between the first set of circles as centers. The result is a set of six circles overlapping the original 12 circles. Decorate your design.

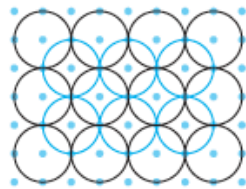

Step 3

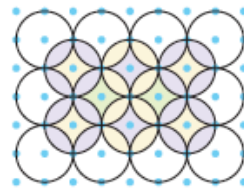

Step 4

Here is another design that you can make using only a compass. Start by constructing a circle, then select any point on it. Without changing your compass setting, swing an arc centered at the selected point. Swing an arc with each of the two new points as centers, and so on.

### The Daisy

Dynamic Geometry Explorations at [www.keymath.com/DG](http://www.keymath.com/DG) show geometric concepts visually using interactive sketches.

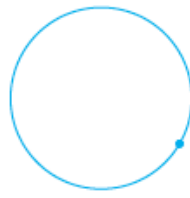

Step 1

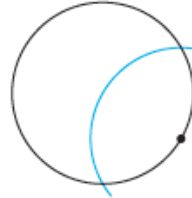

Step 2



Step 3

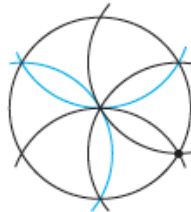

Step 4

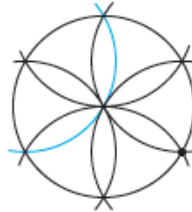

Step 5



Step 6



[keymath.com/DG](http://keymath.com/DG)

[▶ See the **Dynamic Geometry Exploration Daisy Designs** at [www.keymath.com/DG](http://www.keymath.com/DG) .◀]

Notice the shape you get by connecting the six petal tips of the daisy. This is a **regular hexagon**, a 6-sided figure whose sides are the same length and whose angles are all the same size.

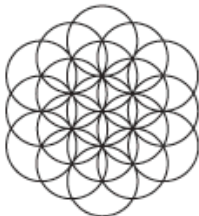

Instead of stopping at the perimeter of the first circle, you can continue to swing full circles. Then you get a "field of daisies," as shown above.



You can do many variations on a daisy design.



12-petal daisy



Field of daisies

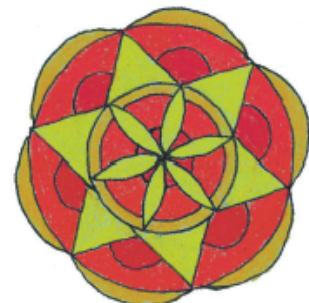

Combination line and circle design  
(Can you see how it was made?)  
Schuyler Smith, geometry student

To create the next design, first locate a point on each of the four sides of a square. Each point should be the same distance from a corner, as shown. Your compass is a good tool for measuring equal lengths. Connect these four points to create another square within the first. Repeat the process until the squares appear to converge on the center. Be careful that you don't fall in!

### The Square Spiral

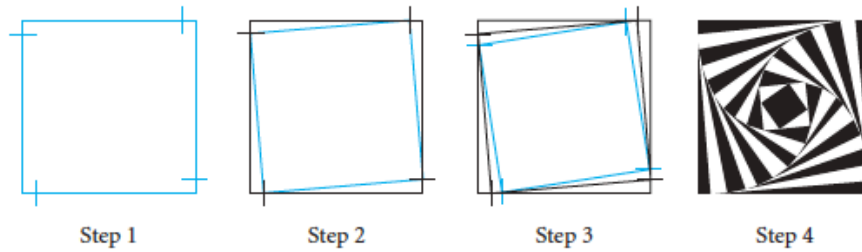

Here are some other examples of op art.

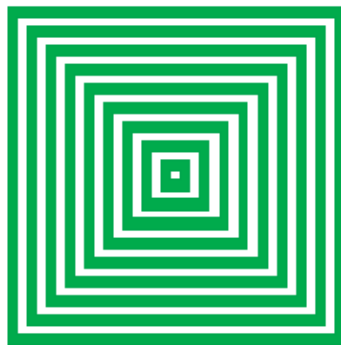

Square tunnel or top of pyramid?

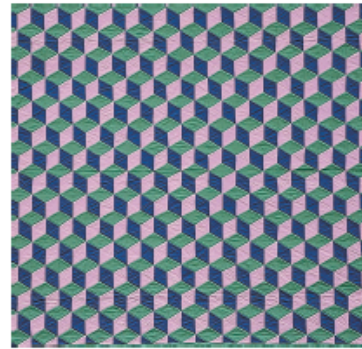

Amish quilt, tumbling block design



Japanese Op Art, Hajime Juchi, Dover Publications

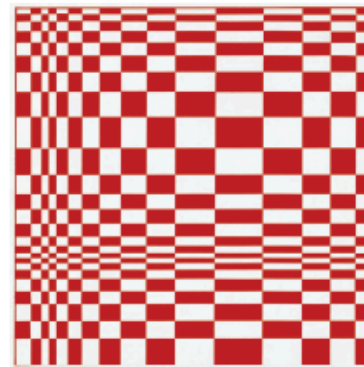

Op art by Carmen Apodaca, geometry student

You can create any of the designs on this page using just a compass and straightedge (and doing some careful coloring). Can you figure out how each of these op art designs was created?

